

# R&S® FSV-K101/-K105

## EUTRA / LTE Uplink Measurement

### Application

# User Manual



1173.1433.02 – 02.1

This manual describes the following software applications:

- R&S FSV-K101 EUTRA / LTE FDD Uplink Measurement Application (1310.9100.02)
- R&S FSV-K105 EUTRA / LTE TDD Uplink Measurement Application (1309.9780.02)

The contents of this manual correspond to the following R&S®FSVR models with firmware version 1.56 or higher:

- R&S®FSVR7 (1311.0006K7)
- R&S®FSVR13 (1311.0006K13)
- R&S®FSVR30 (1311.0006K30)
- R&S®FSVR40 (1311.0006K40)

© 2011 Rohde & Schwarz GmbH & Co. KG

Muehldorfstr. 15, 81671 Munich, Germany

Phone: +49 89 41 29 - 0

Fax: +49 89 41 29 12 164

E-mail: [info@rohde-schwarz.com](mailto:info@rohde-schwarz.com)

Internet: <http://www.rohde-schwarz.com>

Printed in Germany – Subject to change – Data without tolerance limits is not binding.

R&S® is a registered trademark of Rohde & Schwarz GmbH & Co. KG.

Trade names are trademarks of the owners.

The following abbreviations are used throughout this manual: R&S®FSV-K101 is abbreviated as R&S FSV-K101, R&S®FSV-K105 is abbreviated as R&S FSV-K105 and R&S®FSV is abbreviated as R&S FSV.

# Contents

<b>1</b>	<b>Preface</b> .....	<b>5</b>
1.1	Documentation Overview.....	5
1.2	Conventions Used in the Documentation.....	7
1.3	How to Use the Help System.....	8
<b>2</b>	<b>Introduction</b> .....	<b>10</b>
<b>3</b>	<b>Introduction</b> .....	<b>11</b>
3.1	EUTRA / LTE.....	11
3.2	Long-Term Evolution Uplink Transmission Scheme.....	13
3.3	EUTRA / LTE Test & Measurement Assumption made by Rohde & Schwarz .....	17
<b>4</b>	<b>Screen Layout</b> .....	<b>18</b>
<b>5</b>	<b>Configuring Measurements</b> .....	<b>20</b>
5.1	General Settings.....	20
5.2	Demodulation Settings for Uplink Measurements.....	28
5.3	Measurement Settings.....	40
5.4	ACLR Settings.....	42
5.5	SEM Settings.....	43
5.6	Display and Printer Settings.....	43
<b>6</b>	<b>Result Displays</b> .....	<b>44</b>
6.1	Numerical Results.....	44
6.2	Power vs Time Result Displays.....	46
6.3	EVM Results.....	47
6.4	Spectrum Measurements.....	49
6.5	Constellation Diagrams.....	53
6.6	Statistical and Miscellaneous Results.....	55
<b>7</b>	<b>Using the Marker</b> .....	<b>57</b>
<b>8</b>	<b>The Sweep Menu</b> .....	<b>59</b>
<b>9</b>	<b>File Management</b> .....	<b>60</b>
9.1	File Manager.....	60

9.2	SAVE/RECALL Key.....	61
<b>10</b>	<b>Further Information.....</b>	<b>62</b>
10.1	Measurements in Detail.....	62
10.2	References.....	67
10.3	Support.....	68
<b>11</b>	<b>Remote Control.....</b>	<b>69</b>
11.1	Numeric Suffix Definition.....	69
11.2	CALCulate Subsystem.....	70
11.3	CONFigure Subsystem.....	73
11.4	DISPlay Subsystem.....	85
11.5	FETCh Subsystem.....	85
11.6	FORMat Subsystem.....	91
11.7	INITiate Subsystem.....	92
11.8	INPut Subsystem.....	93
11.9	INSTRument Subsystem.....	94
11.10	MMEMory Subsystem.....	98
11.11	SENSe Subsystem.....	98
11.12	TRACe Subsystem.....	104
11.13	TRIGger Subsystem.....	109
11.14	UNIT Subsystem.....	110
11.15	Status Reporting System (LTE Measurements).....	111
	<b>List of Commands.....</b>	<b>115</b>
	<b>Index.....</b>	<b>118</b>

# 1 Preface

## 1.1 Documentation Overview

The user documentation for the R&S FSVR is divided as follows:

- Quick Start Guide
- Operating Manuals for base unit and options
- Service Manual
- Online Help
- Release Notes

### Quick Start Guide

This manual is delivered with the instrument in printed form and in PDF format on the CD. It provides the information needed to set up and start working with the instrument. Basic operations and basic measurements are described. Also a brief introduction to remote control is given. The manual includes general information (e.g. Safety Instructions) and the following chapters:

Chapter 1	Introduction, General information
Chapter 2	Front and Rear Panel
Chapter 3	Preparing for Use
Chapter 4	Firmware Update and Installation of Firmware Options
Chapter 5	Basic Operations
Chapter 6	Basic Measurement Examples
Chapter 7	Brief Introduction to Remote Control
Appendix 1	Printer Interface
Appendix 2	LAN Interface

### Operating Manuals

The Operating Manuals are a supplement to the Quick Start Guide. Operating Manuals are provided for the base unit and each additional (software) option.

The Operating Manual for the base unit provides basic information on operating the R&S FSVR in general, and the "Spectrum" mode in particular. Furthermore, the software options that enhance the basic functionality for various measurement modes are described here. The set of measurement examples in the Quick Start Guide is expanded by more advanced measurement examples. In addition to the brief introduction to remote control in the Quick Start Guide, a description of the basic analyzer commands and programming examples is given. Information on maintenance, instrument interfaces and error messages is also provided.

In the individual option manuals, the specific instrument functions of the option are described in detail. For additional information on default settings and parameters, refer to the data sheets. Basic information on operating the R&S FSVR is not included in the option manuals.

The following Operating Manuals are available for the R&S FSVR:

- R&S FSVR base unit; in addition:
  - R&S FSV-K9 Power Sensor Support
  - R&S FSV-K14 Spectrogram Measurement
- R&S FSV-K7 Analog Demodulation and R&S FSV-K7S FM Stereo Measurements
- R&S FSV-K10 GSM/EDGE Measurement
- R&S FSV-K30 Noise Figure Measurement
- R&S FSV-K40 Phase Noise Measurement
- R&S FSV-K70 Vector Signal Analysis Operating Manual  
R&S FSV-K70 Vector Signal Analysis Getting Started (First measurements)
- R&S FSV-K72 3GPP FDD BTS Analysis
- R&S FSV-K73 3GPP FDD UE Analysis
- R&S FSV-K76/77 3GPP TD-SCDMA BTS/UE Measurement
- R&S FSV-K82/83 CDMA2000 BTS/MS Analysis
- R&S FSV-K84/85 1xEV-DO BTS/MS Analysis
- R&S FSV-K91 WLAN IEEE 802.11a/b/g/j/n
- R&S FSV-K93 WiMAX IEEE 802.16 OFDM/OFDMA Analysis
- R&S FSV-K100/K104 EUTRA / LTE Downlink Measurement Application
- R&S FSV-K101/K105 EUTRA / LTE Uplink Measurement Application

These manuals are available in PDF format on the CD delivered with the instrument. The printed manual can be ordered from Rohde & Schwarz GmbH & Co. KG.

### Service Manual

This manual is available in PDF format on the CD delivered with the instrument. It describes how to check compliance with rated specifications, instrument function, repair, troubleshooting and fault elimination. It contains all information required for repairing the R&S FSVR by replacing modules. The manual includes the following chapters:

Chapter 1	Performance Test
Chapter 2	Adjustment
Chapter 3	Repair
Chapter 4	Software Update / Installing Options
Chapter 5	Documents

### Online Help

The online help contains context-specific help on operating the R&S FSVR and all available options. It describes both manual and remote operation. The online help is installed

on the R&S FSVR by default, and is also available as an executable .chm file on the CD delivered with the instrument.

### Release Notes

The release notes describe the installation of the firmware, new and modified functions, eliminated problems, and last minute changes to the documentation. The corresponding firmware version is indicated on the title page of the release notes. The current release notes are provided in the Internet.

## 1.2 Conventions Used in the Documentation

### 1.2.1 Typographical Conventions

The following text markers are used throughout this documentation:

Convention	Description
"Graphical user interface elements"	All names of graphical user interface elements on the screen, such as dialog boxes, menus, options, buttons, and softkeys are enclosed by quotation marks.
KEYS	Key names are written in capital letters.
File names, commands, program code	File names, commands, coding samples and screen output are distinguished by their font.
<i>Input</i>	Input to be entered by the user is displayed in italics.
<a href="#">Links</a>	Links that you can click are displayed in blue font.
"References"	References to other parts of the documentation are enclosed by quotation marks.

### 1.2.2 Conventions for Procedure Descriptions

When describing how to operate the instrument, several alternative methods may be available to perform the same task. In this case, the procedure using the touch screen is described. Any elements that can be activated by touching can also be clicked using an additionally connected mouse. The alternative procedure using the keys on the instrument or the on-screen keyboard is only described if it deviates from the standard operating procedures.

The term "select" may refer to any of the described methods, i.e. using a finger on the touchscreen, a mouse pointer in the display, or a key on the instrument or on a keyboard.

## 1.3 How to Use the Help System

### Calling context-sensitive and general help

- ▶ To display the general help dialog box, press the HELP key on the front panel.  
The help dialog box "View" tab is displayed. A topic containing information about the current menu or the currently opened dialog box and its function is displayed.



For standard Windows dialog boxes (e.g. File Properties, Print dialog etc.), no context-sensitive help is available.

---

- ▶ If the help is already displayed, press the softkey for which you want to display help.  
A topic containing information about the softkey and its function is displayed.



If a softkey opens a submenu and you press the softkey a second time, the submenu of the softkey is displayed.

---

### Contents of the help dialog box

The help dialog box contains four tabs:

- "Contents" - contains a table of help contents
- "View" - contains a specific help topic
- "Index" - contains index entries to search for help topics
- "Zoom" - contains zoom functions for the help display

To change between these tabs, press the tab on the touchscreen.

### Navigating in the table of contents

- To move through the displayed contents entries, use the UP ARROW and DOWN ARROW keys. Entries that contain further entries are marked with a plus sign.
- To display a help topic, press the ENTER key. The "View" tab with the corresponding help topic is displayed.
- To change to the next tab, press the tab on the touchscreen.

### Navigating in the help topics

- To scroll through a page, use the rotary knob or the UP ARROW and DOWN ARROW keys.
- To jump to the linked topic, press the link text on the touchscreen.

### Searching for a topic

1. Change to the "Index" tab.



2. Enter the first characters of the topic you are interested in. The entries starting with these characters are displayed.
3. Change the focus by pressing the ENTER key.
4. Select the suitable keyword by using the UP ARROW or DOWN ARROW keys or the rotary knob.
5. Press the ENTER key to display the help topic.  
The "View" tab with the corresponding help topic is displayed.

### **Changing the zoom**

1. Change to the "Zoom" tab.
2. Set the zoom using the rotary knob. Four settings are available: 1-4. The smallest size is selected by number 1, the largest size is selected by number 4.

### **Closing the help window**

- ▶ Press the ESC key or a function key on the front panel.

## 2 Introduction

### Overview of the LTE measurement application

This manual contains all information that you need to work with the LTE measurement application like manual operation or remote control operation.

The manual covers all LTE Uplink firmware applications that are available for the R&S FSVR:

- R&S FSV-K101 (LTE Uplink FDD)
- R&S FSV-K105 (LTE Uplink TDD)

The LTE measurement applications make use of the I/Q capture functionality of the R&S FSVR. The I/Q capture enables EUTRA/LTE TX measurements in accordance with the EUTRA specification.

This part of the documentation covers only functions that are particular to the firmware application. For all other functionality, refer to the description of the base unit.

## 3 Introduction

The R&S FSVR-K101/-K105 EUTRA/LTE Uplink Measurement Application uses the I/Q capture functionality of the R&S FSVR spectrum analyzer to enable EUTRA/LTE TX measurements in line with the EUTRA specification.

This manual supports the user in working with this software. It describes how to prepare, execute, and evaluate a measurement and gives many helpful hints and examples.

### 3.1 EUTRA / LTE

Currently, UMTS networks worldwide are being upgraded to high speed downlink packet access (HSDPA) in order to increase data rate and capacity for downlink packet data. In the next step, high speed uplink packet access (HSUPA) will boost uplink performance in UMTS networks. While HSDPA was introduced as a 3GPP Release 5 feature, HSUPA is an important feature of 3GPP Release 6. The combination of HSDPA and HSUPA is often referred to as HSPA.

However, even with the introduction of HSPA, the evolution of UMTS has not reached its end. HSPA+ will bring significant enhancements in 3GPP Release 7. The objective is to enhance the performance of HSPA-based radio networks in terms of spectrum efficiency, peak data rate and latency, and to exploit the full potential of WCDMA-based 5 MHz operation. Important features of HSPA+ are downlink multiple input multiple output (MIMO), higher order modulation for uplink and downlink, improvements of layer 2 protocols, and continuous packet connectivity.

In order to ensure the competitiveness of UMTS for the next 10 years and beyond, concepts for UMTS long term evolution (LTE) have been investigated. The objective is a high-data-rate, low-latency and packet-optimized radio access technology. Therefore, a study item was launched in 3GPP Release 7 on evolved UMTS terrestrial radio access (EUTRA) and evolved UMTS terrestrial radio access network (EUTRAN). LTE/EUTRA will then form part of 3GPP Release 8 core specifications.

This introduction focuses on LTE/EUTRA technology. In the following, the terms LTE or EUTRA are used interchangeably.

requirements, e.g. targets for data rate, capacity, spectrum efficiency, and latency. Also commercial aspects such as costs for installing and operating the network were considered. Based on these requirements, technical concepts for the air interface transmission schemes and protocols were studied. Notably, LTE uses new multiple access schemes on the air interface: orthogonal frequency division multiple access (OFDMA) in downlink and single carrier frequency division multiple access (SC-FDMA) in uplink. Furthermore, MIMO antenna schemes form an essential part of LTE. In an attempt to simplify protocol architecture, LTE brings some major changes to the existing UMTS protocol concepts. Impact on the overall network architecture including the core network is being investigated in the context of 3GPP system architecture evolution (SAE).

### 3.1.1 Requirements for UMTS Long-Term Evolution

LTE is focusing on optimum support of packet switched (PS) services. Main requirements for the design of an LTE system are documented in 3GPP TR 25.913 [1] and can be summarized as follows:

- **Data Rate:** Peak data rates target 100 Mbps (downlink) and 50 Mbps (uplink) for 20 MHz spectrum allocation, assuming two receive antennas and one transmit antenna are at the terminal.
- **Throughput:** The target for downlink average user throughput per MHz is three to four times better than Release 6. The target for uplink average user throughput per MHz is two to three times better than Release 6.
- **Spectrum efficiency:** The downlink target is three to four times better than Release 6. The uplink target is two to three times better than Release 6.
- **Latency:** The one-way transit time between a packet being available at the IP layer in either the UE or radio access network and the availability of this packet at IP layer in the radio access network/UE shall be less than 5 ms. Also C-plane latency shall be reduced, e.g. to allow fast transition times of less than 100 ms from camped state to active state.
- **Bandwidth:** Scaleable bandwidths of 5 MHz, 10 MHz, 15 MHz, and 20 MHz shall be supported. Also bandwidths smaller than 5 MHz shall be supported for more flexibility.
- **Interworking:** Interworking with existing UTRAN/GERAN systems and non-3GPP systems shall be ensured. Multimode terminals shall support handover to and from UTRAN and GERAN as well as inter-RAT measurements. Interruption time for handover between EUTRAN and UTRAN/GERAN shall be less than 300 ms for realtime services and less than 500 ms for non-realtime services.
- **Multimedia broadcast multicast services (MBMS):** MBMS shall be further enhanced and is then referred to as E-MBMS.
- **Costs:** Reduced CAPEX and OPEX including backhaul shall be achieved. Cost-effective migration from Release 6 UTRA radio interface and architecture shall be possible. Reasonable system and terminal complexity, cost, and power consumption shall be ensured. All the interfaces specified shall be open for multivendor equipment interoperability.
- **Mobility:** The system should be optimized for low mobile speed (0 to 15 km/h), but higher mobile speeds shall be supported as well, including high speed train environment as a special case.
- **Spectrum allocation:** Operation in paired (frequency division duplex / FDD mode) and unpaired spectrum (time division duplex / TDD mode) is possible.
- **Co-existence:** Co-existence in the same geographical area and co-location with GERAN/UTRAN shall be ensured. Also, co-existence between operators in adjacent bands as well as cross-border co-existence is a requirement.
- **Quality of Service:** End-to-end quality of service (QoS) shall be supported. VoIP should be supported with at least as good radio and backhaul efficiency and latency as voice traffic over the UMTS circuit switched networks.
- **Network synchronization:** Time synchronization of different network sites shall not be mandated.

## 3.2 Long-Term Evolution Uplink Transmission Scheme

### 3.2.1 SC-FDMA

During the study item phase of LTE, alternatives for the optimum uplink transmission scheme were investigated. While OFDMA is seen optimum to fulfil the LTE requirements in downlink, OFDMA properties are less favourable for the uplink. This is mainly due to weaker peak-to-average power ratio (PAPR) properties of an OFDMA signal, resulting in worse uplink coverage.

Thus, the LTE uplink transmission scheme for FDD and TDD mode is based on SCFDMA with a cyclic prefix. SC-FDMA signals have better PAPR properties compared to an OFDMA signal. This was one of the main reasons for selecting SC-FDMA as LTE uplink access scheme. The PAPR characteristics are important for cost-effective design of UE power amplifiers. Still, SC-FDMA signal processing has some similarities with OFDMA signal processing, so parameterization of downlink and uplink can be harmonized.

There are different possibilities how to generate an SC-FDMA signal. DFT-spread- OFDM (DFT-s-OFDM) has been selected for EUTRA. The principle is illustrated in [Figure 1-1](#).

For DFT-s-OFDM, a size-M DFT is first applied to a block of M modulation symbols. QPSK, 16QAM and 64 QAM are used as uplink EUTRA modulation schemes, the latter being optional for the UE. The DFT transforms the modulation symbols into the frequency domain. The result is mapped onto the available sub-carriers. In EUTRA uplink, only localized transmission on consecutive sub-carriers is allowed. An N point IFFT where  $N > M$  is then performed as in OFDM, followed by addition of the cyclic prefix and parallel to serial conversion.

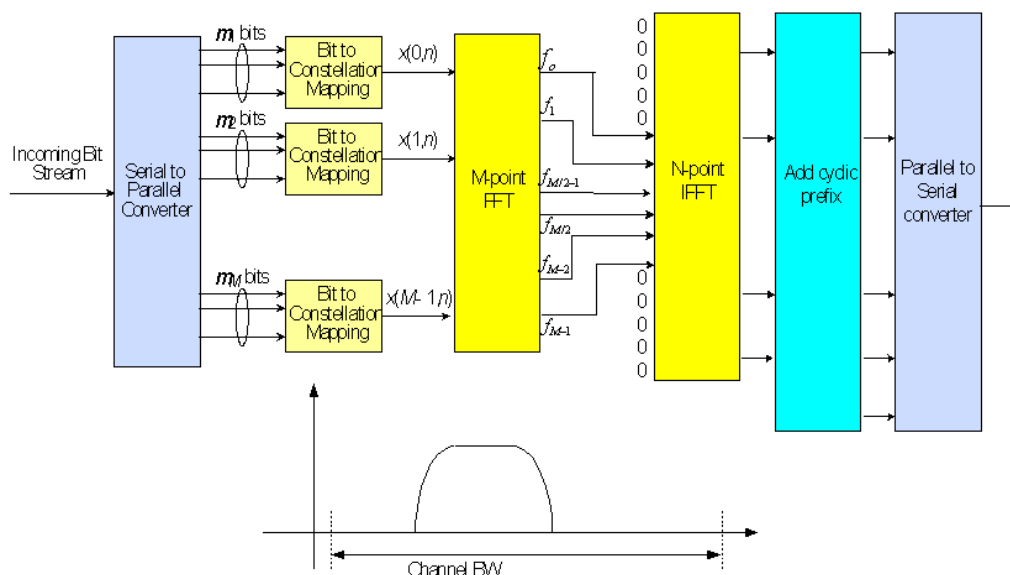

Fig. 3-1: Block Diagram of DFT-s-OFDM (Localized Transmission)

The DFT processing is therefore the fundamental difference between SC-FDMA and OFDMA signal generation. This is indicated by the term DFT-spread-OFDM. In an SCFDMA signal, each sub-carrier used for transmission contains information of all transmitted modulation symbols, since the input data stream has been spread by the DFT transform over the available sub-carriers. In contrast to this, each sub-carrier of an OFDMA signal only carries information related to specific modulation symbols.

### 3.2.2 SC-FDMA Parameterization

The EUTRA uplink structure is similar to the downlink. An uplink radio frame consists of 20 slots of 0.5 ms each, and 1 subframe consists of 2 slots. The slot structure is shown in Figure 1-2.

Each slot carries  $N_{\text{ymb}}^{\text{UL}}$  SC-FDMA symbols, where  $N_{\text{ymb}}^{\text{UL}} = 7$  for the normal cyclic prefix and  $N_{\text{ymb}}^{\text{UL}} = 6$  for the extended cyclic prefix. SC-FDMA symbol number 3 (i.e. the 4th symbol in a slot) carries the reference signal for channel demodulation.

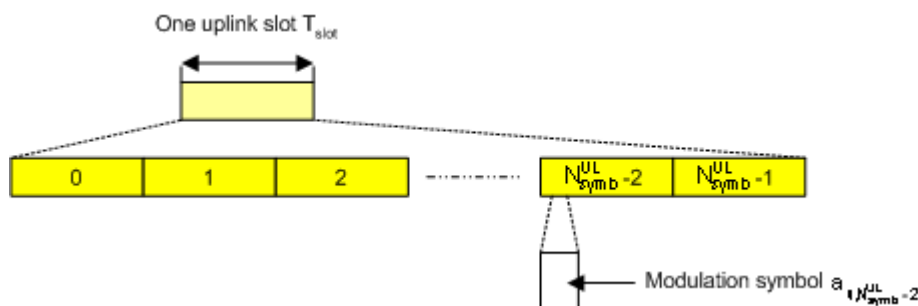

Fig. 3-2: Uplink Slot Structure

Also for the uplink, a bandwidth agnostic layer 1 specification has been selected. The table below shows the configuration parameters in an overview table.

Configuration	Number of symbols $N_{\text{ymb}}^{\text{UL}}$	Cyclic prefix length in samples	Cyclic prefix length in $\mu\text{s}$
Normal cyclic prefix $\Delta f=15\text{kHz}$	7	160 for first symbol 144 for other symbols	5.2 $\mu\text{s}$ for first symbol 4.7 $\mu\text{s}$ for other symbols
Extended cyclic prefix $\Delta f=15\text{kHz}$	6	512	16.7 $\mu\text{s}$

### 3.2.3 Uplink Data Transmission

In uplink, data is allocated in multiples of one resource block. Uplink resource block size in the frequency domain is 12 sub-carriers, i.e. the same as in downlink. However, not all integer multiples are allowed in order to simplify the DFT design in uplink signal processing. Only factors 2, 3, and 5 are allowed.

The uplink transmission time interval (TTI) is 1 ms (same as downlink).

User data is carried on the Physical Uplink Shared Channel (**PUSCH**) that is determined by the transmission bandwidth  $N_{\text{Tx}}$  and the frequency hopping pattern  $k_0$ .

The Physical Uplink Control Channel (**PUCCH**) carries uplink control information, e.g. CQI reports and ACK/NACK information related to data packets received in the downlink. The PUCCH is transmitted on a reserved frequency region in the uplink.

### 3.2.4 Uplink Reference Signal Structure

Uplink reference signals are used for two different purposes: on the one hand, they are used for channel estimation in the eNodeB receiver in order to demodulate control and data channels. On the other hand, the reference signals provide channel quality information as a basis for scheduling decisions in the base station. The latter purpose is also called channel sounding.

The uplink reference signals are based on CAZAC (Constant Amplitude Zero Auto-Correlation) sequences.

### 3.2.5 Uplink Physical Layer Procedures

For EUTRA, the following uplink physical layer procedures are especially important:

#### Non-synchronized random access

Random access may be used to request initial access, as part of handover, when transitioning from idle to connected, or to re-establish uplink synchronization. The structure is shown in figure 3-3.

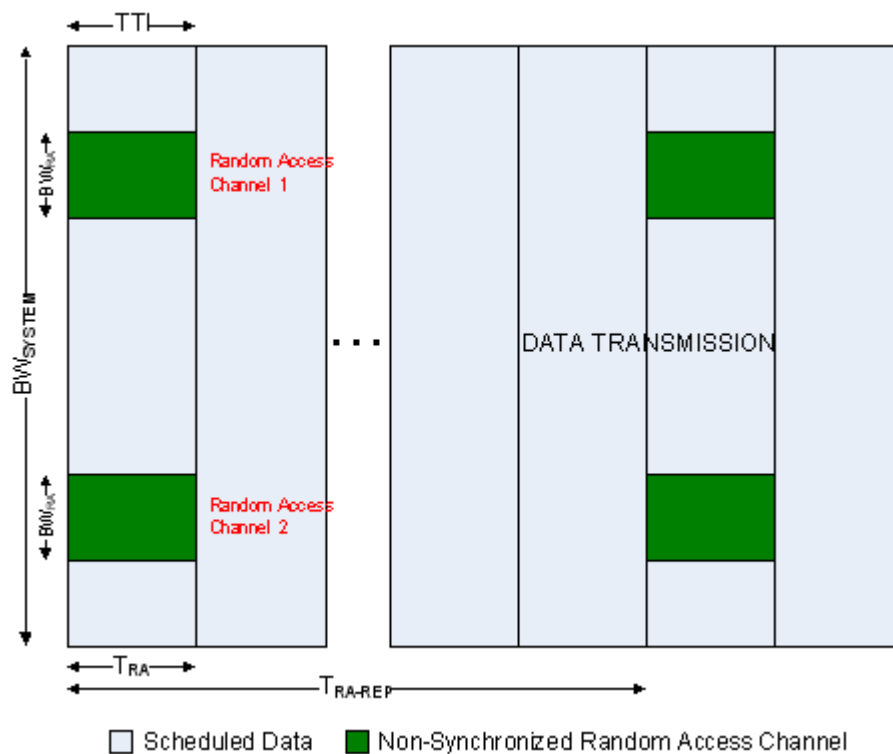
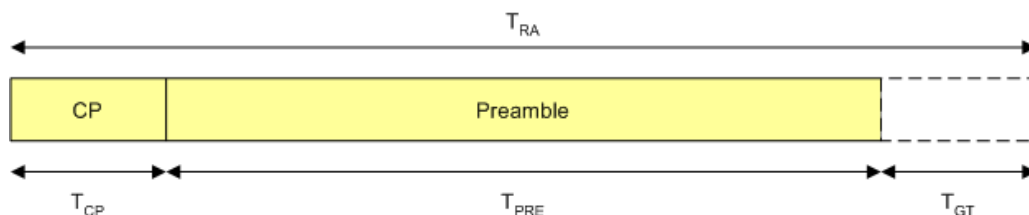

Fig. 3-3: Random Access Structure, principle

Multiple random access channels may be defined in the frequency domain within one access period  $T_{RA}$  in order to provide a sufficient number of random access opportunities.

For random access, a preamble is defined as shown in figure 3-4. The preamble sequence occupies  $T_{PRE} = 0.8$  ms and the cyclic prefix occupies  $T_{CP} = 0.1$  ms within one subframe of 1 ms. During the guard time  $T_{GT}$ , nothing is transmitted. The preamble bandwidth is 1.08 MHz (72 sub-carriers). Higher layer signalling controls in which subframes the preamble transmission is allowed, and the location in the frequency domain. Per cell, there are 64 random access preambles. They are generated from Zadoff-Chu sequences.



**Fig. 3-4: Random Access Preamble**

The random access procedure uses open loop power control with power ramping similar to WCDMA. After sending the preamble on a selected random access channel, the UE waits for the random access response message. If no response is detected then another random access channel is selected and a preamble is sent again.

### Uplink scheduling

Scheduling of uplink resources is done by eNodeB. The eNodeB assigns certain time/frequency resources to the UEs and informs UEs about transmission formats to use. Scheduling decisions affecting the uplink are communicated to the UEs via the Physical Downlink Control Channel (PDCCH) in the downlink. The scheduling decisions may be based on QoS parameters, UE buffer status, uplink channel quality measurements, UE capabilities, UE measurement gaps, etc.

### Uplink link adaptation

As uplink link adaptation methods, transmission power control, adaptive modulation and channel coding rate, as well as adaptive transmission bandwidth can be used.

### Uplink timing control

Uplink timing control is needed to time align the transmissions from different UEs with the receiver window of the eNodeB. The eNodeB sends the appropriate timing-control commands to the UEs in the downlink, commanding them to adapt their respective transmit timing.

### Hybrid automatic repeat request (ARQ)

The Uplink Hybrid ARQ protocol is already known from HSUPA. The eNodeB has the capability to request retransmissions of incorrectly received data packets.



### 3.3 EUTRA / LTE Test & Measurement Assumption made by Rohde & Schwarz

The following assumptions are valid for all current implementations on R&S signal generators and R&S signal analyzers.

#### OFDMA Parameterization

In order to configure the bandwidth of the signal to be generated and analyzed, the desired number of resource blocks can be specified in a range from 6 to 110 resource blocks with a granularity of 1. This results in bandwidths from 1.08 MHz...19.8 MHz.

The resulting FFT size is derived from the following formula:

$$N_{FFT} = 2^{\text{nextpow2}(\lceil 1.4 \cdot (12n+1) \rceil)}$$

- n is the selected number of resource blocks
- nextpow2(N) returns the first P such that  $2^P \geq \text{abs}(N)$
- $\lceil \rceil$  rounds up to the next highest integer

## 4 Screen Layout

After starting the application, the screen takes on the following layout:

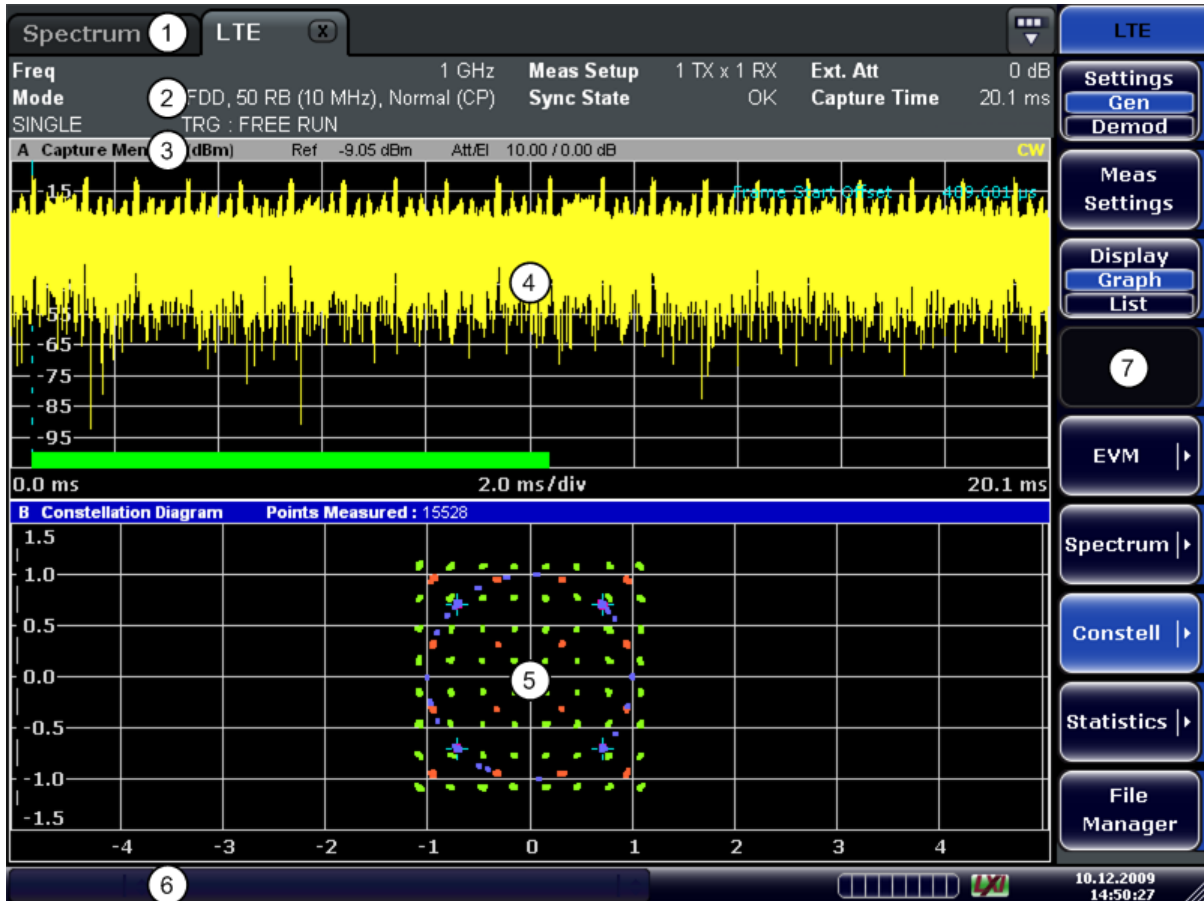

- 1 = Title Bar: shows the currently active measurement application
- 2 = Table Header: shows basic measurement information, e.g. the frequency
- 3 = Result Display Header: shows information about the display trace
- 4 = Result Display Screen A: shows the measurement results
- 5 = Result Display Screen B: shows the measurement results
- 6 = Status Bar: shows the measurement progress, software messages and errors
- 7 = Softkeys: open settings dialogs and select result displays

### Status Bar

The status bar is located at the bottom of the display. It shows the current measurement status and its progress in a running measurement. The status bar also shows warning and error messages. Error messages are generally highlighted.

### Display of Measurement Settings

The header table above the result display shows information on hardware and measurement settings.

LTE <span>✕</span>					
<b>Freq</b>		1 GHz	<b>Meas Setup</b>	1 TX x 1 RX	<b>Ext. Att</b> 0 dB
<b>Mode</b>	DL FDD, 50 RB (10 MHz), Normal (CP)		<b>Sync State</b>	OK	<b>Capture Time</b> 20.1 ms
SINGLE	TRG : FREE RUN				

The header table includes the following information

- **Freq**  
The analyzer RF frequency.
- **Mode**  
Link direction, duplexing, cyclic prefix and maximum number of physical resource blocks (PRBs) / signal bandwidth.
- **Meas Setup**  
Shows number of transmitting and receiving antennas.
- **Sync State**  
Shows the synchronization state.
- **Ext. Att**  
External attenuation in dB.
- **Capture Time**  
Capture length in ms.

## 5 Configuring Measurements

Before you can start a measurement, you have to configure the R&S FSVR in order to get valid measurement results. The following topics contain detailed information on all settings of the application.

You can access the two main settings dialog boxes via the "Settings (Gen Demod)" softkey. Pressing the softkey once opens the "General Settings" dialog box. The "Gen" label in the softkey turns green to indicate an active "General Settings" dialog box. Pressing the softkey again opens the "Demod Settings" dialog box. When the "Demod Settings" dialog box is active, the "Demod" label in the softkey turns green.

In addition, you can set up general measurement parameters in the "Measurement Settings" dialog box. Special settings for SEM and ACLR measurements are provided by the corresponding dialog boxes.

### 5.1 General Settings

In the General Settings dialog box, you can set all parameters that are related to the overall measurement. The dialog box is made up of two tabs, one for general settings and one for advanced settings. By default, the "General" tab is the active one. You can switch between the tabs by touching the tab on the touchscreen or with the cursor keys.

#### 5.1.1 General

The "UL General" settings contain basic measurement and signal settings.

##### 5.1.1.1 Signal Characteristics

Signal characteristics include settings to describe the basic physical attributes of the LTE signal.

You can find the signal characteristics in the "General Settings" dialog box.

UL General		Advanced
<b>Signal Characteristics</b>		
Standard	3GPP LTE TDD Downl ▾	
Frequency	1.8 GHz	
Channel Bandwidth <i>BW</i>	10 MHz	
Number of RB	50	
FFT Size <i>N<sub>FFT</sub></i>	1024	
Sampling Rate	15.36 MHz	
Cyclic Prefix	Auto	

#### Standard

The choices you have depend on the configuration of the R&S FSVR.

- option R&S FSVR-K100 enables testing of 3GPP LTE FDD signals on the downlink

- option R&S FSVR-K101 enables testing of 3GPP LTE FDD signals on the uplink
- option R&S FSVR-K104 enables testing of 3GPP LTE TDD signals on the downlink
- option R&S FSVR-K105 enables testing of 3GPP LTE TDD signals on the uplink

FDD and TDD are duplexing methods.

- FDD mode uses different frequencies for the uplink and the downlink.
- TDD mode uses the same frequency for the uplink and the downlink.

Downlink (DL) and Uplink (UL) describe the transmission path.

- Downlink is the transmission path from the base station to the user equipment. The physical layer mode for the downlink is always OFDMA.
- Uplink is the transmission path from the user equipment to the base station. The physical layer mode for the uplink is always SC-FDMA.

SCPI command:

[CONFigure\[:LTE\]:LDIRection](#) on page 74

[CONFigure\[:LTE\]:DUPLexing](#) on page 74

### Frequency

Sets the frequency of the signal and thus the center frequency of the R&S FSVR.

The available frequency range depends on the hardware configuration of the R&S FSVR you have in use.

The header table shows the current center frequency.

SCPI command:

[\[SENSe\]:FREQuency:CENTer](#) on page 102

### Channel Bandwidth and Number of Resource Blocks

Specifies the channel bandwidth and the number of resource blocks (RB).

The channel bandwidth and number of resource blocks (RB) are interdependent. If you enter one, the R&S FSVR automatically calculates and adjusts the other.

Currently, the LTE standard recommends six bandwidths (see table below).

If you enter a value different to those recommended by the standard, the R&S FSVR labels the parameter as "User", but still does the calculations.

The R&S FSVR also calculates the FFT size, sampling rate, occupied bandwidth and occupied carriers from the channel bandwidth. Those are read only.

Channel Bandwidth [MHz]	1.4	3	5	10	15	20
Number of Resource Blocks	6	15	25	50	75	100
Sample Rate [MHz]	1.92	3.84	7.68	15.36	23.04	30.72
FFT Size	128	256	512	1024	2048	2048

For more information on the calculation method of the FFT size see [E-UTRA / LTE Test & Measurement Assumption made by Rohde & Schwarz](#).

SCPI command:

`CONFigure[:LTE]:UL:BW` on page 74

`CONFigure[:LTE]:UL:NORB` on page 77

### Cyclic Prefix

The cyclic prefix serves as a guard interval between OFDM symbols to avoid interferences. The standard specifies two cyclic prefix modes with a different length each.

The cyclic prefix mode defines the number of OFDM symbols in a slot.

- Normal  
A slot contains 7 OFDM symbols.
- Extended  
A slot contains 6 OFDM symbols.  
The extended cyclic prefix is able to cover larger cell sizes with higher delay spread of the radio channel.
- Auto  
The application automatically detects the cyclic prefix mode in use.

SCPI command:

`CONFigure[:LTE]:UL:CYCPrefix` on page 75

#### 5.1.1.2 Level Settings

Level settings include general parameters necessary to adjust the R&S FSVR to the power level of the signal.

You can find the level settings in the "General Settings" dialog box.

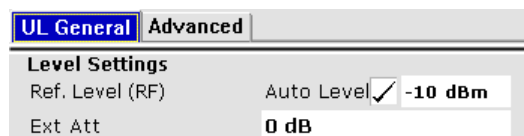

### Reference Level

Sets the reference level of the R&S FSVR.

The reference level is the power level the R&S FSVR expects at the RF input. Keep in mind that the power level at the RF input is the peak envelope power in case of signals with a high crest factor like LTE.

To get the best dynamic range, you have to set the reference level as low as possible. At the same time, make sure that the maximum signal level does not exceed the reference level. If it does, it will overload the A/D converter, regardless of the signal power. Measurement results may deteriorate (e.g. EVM). This applies especially for measurements with more than one active channel near the one you are trying to measure ( $\pm 6$  MHz).

Note that the signal level at the A/D converter may be stronger than the level the R&S FSVR displays, depending on the current resolution bandwidth. This is because the resolution bandwidths are implemented digitally after the A/D converter.

You can either specify the RF reference level (in dBm) or baseband reference level (in V), depending on the [input source](#).

You can also turn on automatic detection of the reference level with the "Auto Level" function.

If active, the R&S FSVR measures and sets the reference level to its ideal value before each sweep and makes sure that the results are accurate. However, measurement time will increase slightly. By default, the R&S FSVR automatically determines the measurement time, but you can define the measurement time of that measurement with the auto level track time.

Automatic level detection also optimizes RF attenuation.

SCPI command:

#### Manual

[CONFigure:POWer:EXPeCted:RF<analyzer>](#) on page 84

#### Automatic

[\[SENSe\]:POWer:AUTO<analyzer>\[:STATe\]](#) on page 102

#### External Attenuation

Sets an external attenuation or gain.

If you attenuate or amplify the RF signal externally, the R&S FSVR adjusts the numeric and graphical results accordingly. In case of graphical power result displays, it moves the trace(s) vertically by the specified value.

Positive values correspond to an attenuation and negative values correspond to an amplification.

SCPI command:

[DISPlay\[:WINDow<n>\]:TRACe<t>:Y\[:SCALE\]:RLEVel:OFFSet](#) on page 85

### 5.1.1.3 Configuring the Data Capture

Data capture includes all functionality that controls the amount and the way the R&S FSVR records the LTE signal data.

You can find the data capture settings in the "General Settings" dialog box.

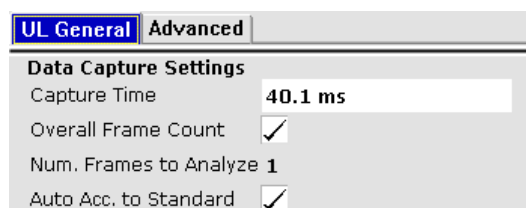

#### Capture Time

Sets the capture time.

The capture time corresponds to the time of one sweep. Hence, it defines the amount of data the R&S FSVR captures during one sweep.

SCPI command:

[\[SENSe\]:SWEep:TIME](#) on page 104

**Overall Frame Count**

Turns the manual selection of the number of frames to capture (and analyze) on and off. If the overall frame count is active, you can define a particular number of frames to capture and analyze. The measurement runs until all required frames have been analyzed, even if it takes more than one sweep.

If the overall frame count is inactive, the R&S FSVR analyzes all complete LTE frames currently in the capture buffer.

SCPI command:

[SENSe] [:LTE] :FRAMe:COUNT:STATe on page 99

**Number of Frames to Analyze**

Sets the number of frames that you want to capture and analyze.

If the number of frames you have set last longer than a single sweep, the R&S FSVR continues the measurement until all frames have been captured.

The parameter is read only if

- the overall frame count is inactive,
- the data is captured according to the standard ([Auto According to Standard](#)).

SCPI command:

[SENSe] [:LTE] :FRAMe:COUNT on page 98

**Auto According to Standard**

Turns automatic selection of the number of frames to capture and analyze on and off.

If active, the R&S FSVR evaluates the number of frames as defined for EVM tests in the LTE standard.

If inactive, you can set the number of frames you want to analyze.

This parameter is not available if the overall frame count is inactive.

SCPI command:

[SENSe] [:LTE] :FRAMe:COUNT:AUTO on page 99

**5.1.1.4 Triggering Measurements**

The trigger settings include all parameters necessary to describe conditions for triggering measurements.

You can find the trigger settings in the "General Settings" dialog box.

UL General		Advanced
<b>Trigger Settings</b>		
Trigger Mode	Free Run	
Trigger Offset	0 s	
Trig. Holdoff	150 ns	
Trig. Hysteresis	3 dB	
Trigger Level	1.4 V	

**Trigger Mode**

Selects the source that triggers a measurement.



The R&S FSVR supports several trigger modes.

- **Free Run**  
When Free Run is active, the measurement starts immediately.
- **External**  
The trigger event is the level of an external trigger signal. The measurement starts when this signal meets or exceeds a specified trigger level at the "Ext Trigger/Gate" input.
- **IF Power**  
The trigger event is the IF power level. The measurement starts when the IF power meets or exceeds a specified power trigger level.
- **RF Power**  
The trigger event is the RF power level. The measurement starts when a signal outside of the measured channel meets or exceeds a certain level at the first intermediate frequency.  
The level range is from -50 dBm to -10 dBm. The corresponding trigger level at the RF input is:  
The RF Power trigger is available with detector board 1307.9554.02 Rev. 05.00 or higher. It is not available for measurements with the digital I/Q interface (R&S FSVR-B17).
- **Power Sensor**  
The trigger event is a specified level measured by a power sensor. The measurement starts when a power sensor measurement meets certain conditions.  
The power sensor as a trigger source is only available with option R&S FSVR-K9 and a connected power sensor.

SCPI command:

[TRIGger\[:SEquence\]:MODE](#) on page 110

#### Trigger Offset

Specifies the delay between the trigger event and the start of the sweep. A negative trigger offset defines a pretrigger.

The trigger offset is unavailable for free run measurements.

SCPI command:

[TRIGger\[:SEquence\]:HOLDoff<analyzer>](#) on page 109

#### Trigger Holdoff

Defines a trigger holdoff.

The trigger holdoff is the time that must pass after the trigger event and before the measurement starts.

The trigger holdoff is available for IF power and RF power triggers.

#### Trigger Hysteresis

Defines the trigger hysteresis.

The trigger hysteresis defines a distance to the trigger level that the input signal must stay below in order to fulfill the trigger condition.

#### Trigger Level

Specifies the trigger level for an external, IF, RF or power sensor trigger.

The name and contents of the field depend on the selected trigger mode. It is available only in combination with the corresponding trigger mode.

SCPI command:

`TRIGger[:SEquence]:LEVel<analyzer>[:EXTernal]` on page 110

## 5.1.2 Advanced

The "Advanced" settings contain parameters to configure more complex measurement setups.

### 5.1.2.1 I/Q Settings

I/Q settings are all settings that define the way the R&S FSVR captures I/Q data.

You can find the I/Q settings in the "General Settings" dialog box.



#### Swap I/Q

Swaps the real (I branch) and the imaginary (Q branch) parts of the signal.

SCPI command:

`[SENSe]:SWAPiq` on page 103

### 5.1.2.2 Input Settings

The input settings provide all functions necessary to control the input source.

You can find the input settings in the "General Settings" dialog box.

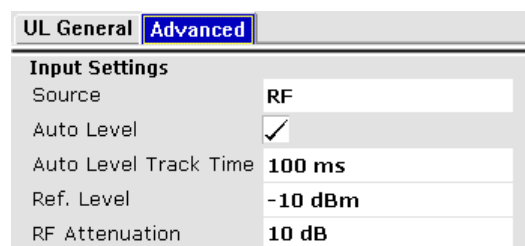

#### Source

Selects the input source of the data.

By default, the R&S FSVR uses its RF input.

With hardware option R&S FSV-B17 you can use the digital baseband input. For more information on using digital baseband data see the manual of the R&S FSVR.

If the data has been recorded and saved already, you can also read the data from a file and analyze it on the R&S FSVR. For more information on how to import I/Q data see [chapter 9, "File Management"](#), on page 60.

SCPI command:

`INPut:SElect` on page 94

### Reference Level

Sets the reference level of the R&S FSVR.

The reference level is the power level the R&S FSVR expects at the RF input. Keep in mind that the power level at the RF input is the peak envelope power in case of signals with a high crest factor like LTE.

To get the best dynamic range, you have to set the reference level as low as possible. At the same time, make sure that the maximum signal level does not exceed the reference level. If it does, it will overload the A/D converter, regardless of the signal power. Measurement results may deteriorate (e.g. EVM). This applies especially for measurements with more than one active channel near the one you are trying to measure ( $\pm 6$  MHz).

Note that the signal level at the A/D converter may be stronger than the level the R&S FSVR displays, depending on the current resolution bandwidth. This is because the resolution bandwidths are implemented digitally after the A/D converter.

You can either specify the RF reference level (in dBm) or baseband reference level (in V), depending on the [input source](#).

You can also turn on automatic detection of the reference level with the "Auto Level" function.

If active, the R&S FSVR measures and sets the reference level to its ideal value before each sweep and makes sure that the results are accurate. However, measurement time will increase slightly. By default, the R&S FSVR automatically determines the measurement time, but you can define the measurement time of that measurement with the auto level track time.

Automatic level detection also optimizes RF attenuation.

SCPI command:

#### Manual

`CONFigure:POWer:EXPeCted:RF<analyzer>` on page 84

#### Automatic

`[SENSe]:POWer:AUTO<analyzer>[:STATe]` on page 102

### RF Attenuation

Sets the mechanical attenuation of the RF signal at the RF input.

RF attenuation is independent of the reference level. It is in the range from 0 dB to 75 dB in steps of 5 dB.

RF attenuation is available if automatic reference level detection is inactive.

For more information on attenuation see the manual of the R&S FSVR.

SCPI command:

`INPut<n>:ATTenuation<analyzer>` on page 93

**EI Att**

Configures the electronic attenuator.

The process of configuring the electronic attenuator consist of three steps.

- **Selecting the mode**  
You can select either manual or automatic control of the electronic attenuator.
- **Selecting the state**  
Turns the electronic attenuator on and off.
- **Setting the attenuation**  
Sets the degree of electronic attenuation.

If you have selected automatic attenuation mode, the R&S FSVR automatically calculates the electronic attenuation. State and degree of attenuation are not available in that case.

If you turn the attenuator off, the degree of attenuation is not available.

Electronic attenuation is available only with option R&S FSVR-B25 and if the frequency range does not exceed the specification of the electronic attenuator.

SCPI command:

[INPut:EATT:AUTO](#) on page 94

**5.1.2.3 Digital I/Q Settings**

The digital I/Q settings define settings related to the digital baseband input.

The digital baseband settings are available only if you have installed option R&S FSVR-B17.

UL General	
<b>Advanced</b>	
<b>Baseband Digital Settings</b>	
Input Data Rate	10 MHz
Full Scale Level	1 V

**Digital Input Data Rate**

Selects the data sample rate at the digital baseband input.

The sample rate is available only if you have selected the digital baseband input source.

SCPI command:

[INPut<n>:DIQ:SRATe](#) on page 93

**Full Scale Level**

Sets the voltage corresponding to the maximum input value of the digital baseband input.

The full scale level is available only if you have selected the digital baseband input source.

SCPI command:

[INPut<n>:DIQ:RANGe\[:UPPer\]](#) on page 93

**5.2 Demodulation Settings for Uplink Measurements**

In the Demod Settings dialog box you can set up the measurement in detail, e.g. the demodulation configuration. The dialog box is made up of three tabs, one for configuring

the signal configuration, one for setting up the frame configuration and one for configuring the control channels and miscellaneous settings. By default, the "UL Demod" tab is the active one. You can switch between the tabs by touching the tab on the touchscreen or with the cursor keys.

## 5.2.1 UL Demod

In the UL Demod tab you can set the signal processing configuration with respect to how the signal is to be measured.

### 5.2.1.1 Data Analysis Settings

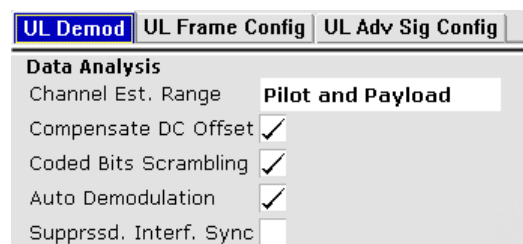

#### Channel Estimation Range

Selects the method for channel estimation.

Choose whether to use only the pilot symbols to perform channel estimation or both pilot and payload carriers.

SCPI command:

[\[SENSe\] \[:LTE\]:UL:DEMod:CESTimation](#) on page 101

#### Compensate DC Offset

Activates or deactivates DC offset compensation when calculating measurement results.

According to 3GPP TS 36.101 (Annex F.4), the R&S FSVR removes the I/Q origin from the evaluated signal before it calculates the EVM and in-band emissions.

SCPI command:

[\[SENSe\] \[:LTE\]:UL:DEMod:CDCoffset](#) on page 100

#### Scrambling of Coded Bits

Turns the scrambling of coded bits for the PUSCH on and off.

The scrambling of coded bits affects the bitstream results.

SCPI command:

[\[SENSe\] \[:LTE\]:UL:DEMod:CBScrambling](#) on page 100

#### Auto Demodulation

Turns automatic demodulation on and off.

If active, the R&S FSVR automatically detects the resource allocation of the signal.

Automatic demodulation is not available if the suppressed interference synchronization is active.

SCPI command:

[\[SENSe\] \[:LTE\] :UL:DEMod:AUTO](#) on page 100

### Suppressed Interference Synchronization

Turns suppressed interference synchronization on and off.

If this synchronization mode is enabled, the synchronization on signals containing more than one user equipment (UE) is more robust. Additionally, the EVM is lower in case the UEs have different frequency offsets. Note that Auto Demodulation is not supported in this synchronization mode and the EVM may be higher in case only one UE is present in the signal.

SCPI command:

[\[SENSe\] \[:LTE\] :UL:DEMod:SISync](#) on page 101

## 5.2.1.2 Tracking

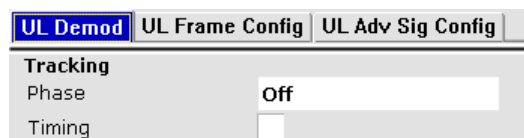

### Phase

Specifies whether or not the measurement results should be compensated for common phase error. When phase compensation is used, the measurement results will be compensated for phase error on a per-symbol basis.

- **Off**  
Phase tracking is not applied.
- **Pilot only**  
Only the reference signal is used.
- **Pilot and Payload**  
Both reference signal and payload resource elements are used.

SCPI command:

[\[SENSe\] \[:LTE\] :UL:TRACking:PHASe](#) on page 101

### Timing

Specifies whether or not the measurement results should be compensated for timing error. When timing compensation is used, the measurement results will be compensated for timing error on a per-symbol basis.

SCPI command:

[\[SENSe\] \[:LTE\] :UL:TRACking:TIME](#) on page 101

## 5.2.2 UL Frame Config

In the UL Frame Config tab you can set the structure of the signal.

### 5.2.2.1 Configuring TDD Frames

Note that you need firmware application R&S FSV-K105 to perform measurements on TDD signals.

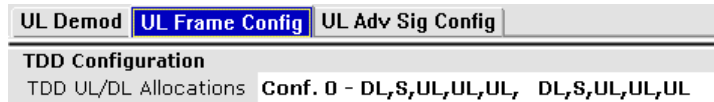

#### Configuring TDD Frames

TDD frames contain both uplink and downlink information separated in time with every subframe being responsible for either uplink or downlink transmission. The standard specifies several subframe configurations or resource allocations for TDD systems.

#### TDD UL/DL Allocations

Selects the configuration of the subframes in a radio frame in TDD systems.

The UL/DL configuration (or allocation) defines the way each subframe is used: for uplink, downlink or if it is a special subframe. The standard specifies seven different configurations.

Configuration	Subframe Number and Usage									
	0	1	2	3	4	5	6	7	8	9
0	D	S	U	U	U	D	S	U	U	U
1	D	S	U	U	D	D	S	U	U	D
2	D	S	U	D	D	D	S	U	D	D
3	D	S	U	U	U	D	D	D	D	D
4	D	S	U	U	D	D	D	D	D	D
5	D	S	U	D	D	D	D	D	D	D
6	D	S	U	U	U	D	S	U	U	D

U = uplink  
D = downlink  
S = special subframe

SCPI command:

Subframe

[CONFigure\[:LTE\]:UL:TDD:UDConf](#) on page 84

### 5.2.2.2 Configuring the Physical Layer Cell Identity

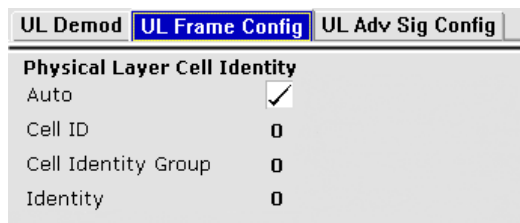

### Configuring the Physical Layer Cell Identity

The cell ID, cell identity group and physical layer identity are interdependent parameters. In combination they are responsible for synchronization between network and user equipment.

The physical layer cell ID identifies a particular radio cell in the LTE network. The cell identities are divided into 168 unique cell identity groups. Each group consists of 3 physical layer identities. According to

$$N_{ID}^{cell} = 3 \cdot N_{ID}^{(1)} + N_{ID}^{(2)}$$

$N^{(1)}$  = cell identity group, {0...167}

$N^{(2)}$  = physical layer identity, {0...2}

there is a total of 504 different cell IDs.

If you change one of these three parameters, the R&S FSVR automatically updates the other two.

The Cell ID determines

- the reference signal grouping hopping pattern
- the reference signal sequence hopping
- the PUSCH demodulation reference signal pseudo-random sequence
- the cyclic shifts for PUCCH formats 1/1a/1b and sequences for PUCCH formats 2/2a/2b
- the pseudo-random sequence used for scrambling
- the pseudo-random sequence used for type 2 PUSCH frequency hopping

#### 5.2.2.3 Configuring Subframes

The application allows you to configure individual subframes.

If you turn "Auto Demodulation" on, the application automatically determines the subframe configuration. In the default state, automatic configuration is on.

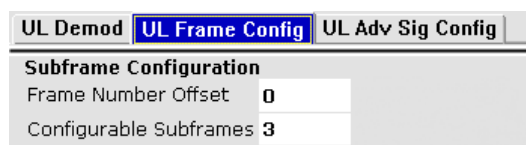

An LTE frame contains 10 subframes. The R&S FSVR shows the contents for each subframe in the configuration table. In the configuration table, each row corresponds to one subframe.

Subframe	Enable PUCCH	Modulation	Number of RB	Offset RB	Power [dB]
0 (not use)	<input type="checkbox"/>				
1 (not use)	<input type="checkbox"/>				
2	<input checked="" type="checkbox"/>	QPSK	10	2	0 dB
	<input type="checkbox"/>				

Before you start to work on the contents of each subframe, you should define the number of subframes you want to customize with the "Configurable Subframes" parameter. The application supports the configuration of up to 10 subframes.



According to the number of configurable subframes you have set, the R&S FSVR adjusts the size of the subframe configuration table. Each row in the table corresponds to one uplink subframe.

The configuration table contains the settings to configure the allocations.

- **Subframe**  
Shows the number of a subframe.  
Note that, depending on the configuration, some subframes may not be available for editing. The R&S FSVR labels those downlink subframes "(not used)". The corresponding cells in the table are greyed out.
- **Enable PUCCH**  
Turns the PUCCH in the corresponding subframe on and off.  
If you enable a PUCCH, "Modulation", "Number of RBs" and "Offset RB" are unavailable.
- **Modulation**  
Selects the modulation scheme for the corresponding PUSCH allocation.  
The modulation scheme is either QPSK, 16QAM or 64QAM.
- **Number of RB**  
Sets the number of resource blocks the PUSCH allocation covers. The number of resource blocks defines the size or bandwidth of the PUSCH allocation.
- **Offset RB**  
Sets the resource block at which the PUSCH allocation begins.
- **Power [dB]**  
Sets the boosting of the allocation. Boosting is the allocation's power relative to the reference signal power.

SCPI command:

#### **Configurable Subframes**

[CONFigure\[:LTE\]:UL:CSUBframes](#) on page 75

#### **Frame Number Offset**

[CONFigure\[:LTE\]:UL:SFNO](#) on page 80

#### **Enable PUCCH**

[CONFigure\[:LTE\]:UL:SUBFrame<subframe>:ALLoc:CONT](#) on page 82

#### **Modulation**

[CONFigure\[:LTE\]:UL:SUBFrame<subframe>:ALLoc:MODulation](#) on page 83

#### **Number of RB**

[CONFigure\[:LTE\]:UL:SUBFrame<subframe>:ALLoc:RBCount](#) on page 83

#### **Offset RB**

[CONFigure\[:LTE\]:UL:SUBFrame<subframe>:ALLoc:RBOffset](#) on page 84

#### **Power**

[CONFigure\[:LTE\]:UL:SUBFrame<subframe>:ALLoc:POWer](#) on page 83

### 5.2.3 UL Advanced Signal Configuration

In the UL Adv Sig Config tab you can describe the advanced structure of the signal.

### 5.2.3.1 Configuring the Demodulation Reference Signal

The Demodulation Reference Signal settings are the settings concerning the configuration of the reference signal for PUSCH and PUCCH.

UL Demod	UL Frame Config	UL Adv Sig Config
<b>Demodulation Reference Signal</b>		
Sequence	3GPP	
Rel. Power PUSCH	0 dB	
Rel. Power PUCCH	0 dB	
Group Hopping	<input type="checkbox"/>	
Sequence Hopping	<input type="checkbox"/>	
Delta Sequence Shift	0	
n_DMRS	0	
Enable n_PRS	<input checked="" type="checkbox"/>	

#### Sequence

Sequence shows the modulation that is used for the reference signal.

This field is read only.

#### Relative Power PUSCH

Sets the power offset of the Demodulation Reference Signal (DRS) relative to the power level of the PUSCH allocation of the corresponding subframe. The selected DRS power offset ( $P_{DRS\_Offset}$ ) applies for all subframes. Depending on the allocation of the subframe, the effective power level of the DRS is calculated as following:

$$P_{DRS} = P_{UE} + P_{PUSCH} + P_{DRS\_Offset}$$

The PUSCH Power level ( $P_{PUSCH}$ ) can vary per subframe.

SCPI command:

[CONFigure\[:LTE\]:UL:DRS\[:PUSCh\]:POWER](#) on page 76

#### Relative Power PUCCH

Sets the power offset of the Demodulation Reference Signal (DRS) relative to the power level of the PUCCH allocation of the corresponding subframe. The selected DRS power offset ( $P_{DRS\_Offset}$ ) applies for all subframes. Depending on the allocation of the subframe, the effective power level of the DRS is calculated as following:

$$P_{DRS} = P_{UE} + P_{PUCCH} + P_{DRS\_Offset} \text{ (for PUCCH allocation)}$$

The PUCCH Power level ( $P_{PUCCH}$ ) can vary per subframe.

SCPI command:

[CONFigure\[:LTE\]:UL:DRS:PUCCh:POWER](#) on page 76

#### Group Hopping

Indicates whether group hopping for the demodulation reference signal is activated or not.

17 different hopping patterns and 30 different sequence shift patterns are used for group hopping. PUSCH and PUCCH use the same group hopping pattern that is calculated if the group hopping is enabled. The group hopping pattern is generated by a pseudo-random sequence generator.

SCPI command:

[CONFigure\[:LTE\]:UL:DRS:GRPHopping](#) on page 76

### Sequence Hopping

Indicates whether sequence hopping is activated or not.

SCPI command:

[CONFigure\[:LTE\]:UL:DRS:SEQHopping](#) on page 76

### Delta Sequence Shift

Delta Sequence Shift specifies the parameter  $\Delta_{SS}$

This parameter can be found in 3GPP TS 36.211 V8.5.0, 5.5.1.3 Group hopping. A sequence shift function  $f_{ss}$  is defined for the PUCCH. The corresponding function for the PUSCH is derived by applying this Delta Sequence Shift.

SCPI command:

[CONFigure\[:LTE\]:UL:DRS:DSShift](#) on page 75

### n\_DMRS

The n\_DMRS parameter can be found in 3GPP TS36.211 V8.5.0, 5.5.2.1.1 Reference signal sequence. Currently, n\_DMRS is defined as  $n_{DMRS} = n_{DMRS}^{(1)} + n_{DMRS}^{(2)}$ .

### Enable n\_PRS

Enables the use of the pseudo-random sequence n\_PRS in the calculation of the demodulation reference signal (DMRS) index as defined in 3GPP TS 36.211, chapter 5.5.2.1.1.

If n\_PRS is disabled, it is possible to set the cyclic shift to 0 for all subframes.

This parameter has to be enabled in order to generate a 3GPP compliant uplink signal.

## 5.2.3.2 Configuring the Sounding Reference Signal

The Sounding Reference Signal settings are the general settings concerning the physical attributes of the sounding reference signal.

UL Demod	UL Frame Config	UL Adv Sig Config
<b>Sounding Reference Signal</b>		
Present	<input type="checkbox"/>	
Sequence	3GPP	
Rel. Power	0 dB	
SRS Subframe Conf.	0	
SRS BW B_SRS	0	
Freq. Dmn. Pos. n_RRC	0	
SRS BW Conf. C_SRS	0	
Transm. Comb. k_TC	0	
SRS Cyclic Shift N_CS	0	
Conf. Index I_SRS	0	
Hopping BW b_hop	0	

**Present**

Indicates whether the sounding reference signal is present or not.

SCPI command:

[CONFfigure\[:LTE\]:UL:SRS:STAT](#) on page 82

**Sequence**

Sequence shows which modulation is used for the sounding signal.

Always shows 3GPP.

**Rel. Power**

Relative Power of the sounding reference signal.

SCPI command:

[CONFfigure\[:LTE\]:UL:SRS:POWer](#) on page 82

**SRS Subframe Conf.**

Sets the cell specific parameter SRS subframe configuration. The UEs will send shortened PUSCH/PUCCH in these cell-specific subframes, regardless whether the UEs are configured to send a SRS in the according subframe or not.

SCPI command:

[CONFfigure\[:LTE\]:UL:SRS:SUConfig](#) on page 82

**SRS Bandwidth B\_SRS**

Sets the UE specific parameter SRS Bandwidth BSRS, as defined in the 3GPP TS 36.211, chapter 5.5.3.2.

The SRS can spans the entire frequency bandwidth or can employ frequency hopping where several narrowband SRSs cover the same total bandwidth.

There are up to four SRS bandwidths defined in the standard. The most narrow SRS bandwidth (B\_SRS = 3) spans four resource blocks and is available for all channel bandwidths; the other three values of the parameter B\_SRS define more wideband SRS bandwidths, available depending on the channel bandwidth.

The SRS transmission bandwidth is determined additionally by the SRS Bandwidth Configuration  $C_{SRS}$ .

SCPI command:

[CONFigure\[:LTE\]:UL:SRS:BSRS](#) on page 80

#### **Freq. Domain Pos. n<sub>RRC</sub>**

Sets the UE specific parameter Freq. Domain Position  $n_{RRC}$ , as defined in the 3GPP TS 36.211, chapter 5.5.3.2.

This parameter determines the starting physical resource block of the SRS transmission.

SCPI command:

[CONFigure\[:LTE\]:UL:SRS:NRRC](#) on page 81

#### **SRS BW Conf. C<sub>SRS</sub>**

Sets the cell specific parameter SRS Bandwidth Configuration ( $C_{SRS}$ ).

The SRS Bandwidth Configuration  $C_{SRS}$ , the SRS Bandwidth  $B_{SRS}$  and the UL Channel Bandwidth determine the length of the sounding reference signal sequence, calculated according to 3GPP TS 36.211.

SCPI command:

[CONFigure\[:LTE\]:UL:SRS:CSRS](#) on page 81

#### **Transm. Comb. k<sub>TC</sub>**

Sets the UE specific parameter transmission comb  $k_{TC}$ , as defined in the 3GPP TS 36.211, chapter 5.5.3.2.

SCPI command:

[CONFigure\[:LTE\]:UL:SRS:TRComb](#) on page 82

#### **SRS Cyclic Shift N<sub>CS</sub>**

Sets the cyclic shift  $n_{CS}$  used for the generation of the sounding reference signal CAZAC sequence.

Since the different shifts of the same Zadoff-Chu sequence are orthogonal to each other, applying different SRS cyclic shifts can be used to schedule different users to transmit simultaneously their sounding reference signal.

SCPI command:

[CONFigure\[:LTE\]:UL:SRS:CYCS](#) on page 81

#### **Conf. Index I<sub>SRS</sub>**

Sets the UE specific parameter SRS configuration index  $I_{SRS}$ . Depending on the selected Duplexing Mode, this parameter determines the parameters SRS Periodicity  $T_{SRS}$  and SRS Subframe Offset  $T_{offset}$  as defined in the 3GPP TS 36.213, Table 8.2-1 (FDD) and 8.2-2 (TDD) respectively.

SCPI command:

[CONFigure\[:LTE\]:UL:SRS:ISRS](#) on page 81

#### **Hopping BW b<sub>hop</sub>**

Sets the UE specific parameter frequency hopping bandwidth  $b_{hop}$ , as defined in the 3GPP TS 36.211, chapter 5.5.3.2.

SRS frequency hopping is enabled, if  $b_{\text{HOP}} < B_{\text{SRS}}$ .

SCPI command:

[CONFigure\[:LTE\]:UL:SRS:BHOP](#) on page 80

### 5.2.3.3 Defining the PUSCH Structure

UL Demod	UL Frame Config	UL Adv Sig Config
<b>PUSCH Structure</b>		
Freq. Hopping Mode	Off	
PUSCH Hopping Offset	4	
Number of Subbands	4	
Info. in Hopping Bits	0	

#### Frequency Hopping Mode

Frequency Hopping Mode specifies the hopping mode which is applied to the PUSCH. Available choices are NONE, Inter Subframe and Intra Subframe.

SCPI command:

[CONFigure\[:LTE\]:UL:PUSCh:FHMode](#) on page 79

#### PUSCH Hopping Offset

Sets the PUSCH Hopping Offset  $N_{\text{RB}}^{\text{HO}}$ .

The PUSCH Hopping Offset determines the first physical resource block and the maximum number of physical resource blocks available for PUSCH transmission if PUSCH frequency hopping is used.

SCPI command:

[CONFigure\[:LTE\]:UL:PUSCh:FHOOffset](#) on page 79

#### Number of Subbands

Number of Subbands specifies the number of subbands for PUSCH.

This parameter can be found in 3GPP TS36.211 V8.5.0, 5.5.3.2 Mapping to physical resources.

SCPI command:

[CONFigure\[:LTE\]:UL:PUSCh:NOSM](#) on page 80

#### Info. in Hopping Bits

Sets the information in hopping bits according to the PDCCH DCI format 0 hopping bit definition. This information determines whether type 1 or type 2 hopping is used in the subframe, and - in case of type 1 - additionally determines the exact hopping function to use.

Frequency hopping is applied according to 3GPP TS36.213.

SCPI command:

[CONFigure\[:LTE\]:UL:PUSCh:FHOP:IIHB](#) on page 79

### 5.2.3.4 Defining the PUCCH Structure

UL Demod	UL Frame Config	UL Adv Sig Config
<b>PUCCH Structure</b>		
Num. of RB for PUCCH	0	
Delta Shift	2	
Delta Offset	0	
N(1)_cs	6	
N(2)_RB	1	
Format	F1 normal	
N_PUCCH	0	

### Number of RBs for PUCCH

Number of RBs for PUCCH configures the number of resource blocks for PUCCH.

The resource blocks for PUCCH are always allocated at the edges of the LTE spectrum. If an even number of PUCCH resource blocks are specified, half of the available number of PUCCH resource blocks are allocated on the lower and upper edge of the LTE spectrum (outermost resource blocks). In case an odd number of PUCCH resource blocks are specified, the number of resource blocks on the lower edge is one resource block larger than the number of resource blocks on the upper edge of the LTE spectrum.

SCPI command:

[CONFigure\[:LTE\]:UL:PUCCh:NORB](#) on page 79

### Delta Shift

Sets the delta shift parameter, i.e. the cyclic shift difference between two adjacent PUCCH resource indices with the same orthogonal cover sequence (OC).

The delta shift determines the number of available sequences in a resource block that can be used for PUCCH formats 1/1a/1b.

This parameter can be found in 3GPP TS36.211 V8.5.0, 5.4 Physical uplink control channel.

SCPI command:

[CONFigure\[:LTE\]:UL:PUCCh:DEShift](#) on page 78

### Delta Offset

Sets the PUCCH delta offset parameter, i.e. the cyclic shift offset. The value range depends on the selected Cyclic Prefix.

This parameter can be found in 3GPP TS36.211 V8.5.0, 5.4 Physical uplink control channel.

SCPI command:

[CONFigure\[:LTE\]:UL:PUCCh:DEOffset](#) on page 77

### N(1)\_cs

Sets the number of cyclic shifts used for PUCCH format 1/1a/1b in a resource block used for a combination of the formats 1/1a/1b and 2/2a/2b.

Only one resource block per slot can support a combination of the PUCCH formats 1/1a/1b and 2/2a/2b.

The number of cyclic shifts available for PUCCH format 2/2a/2b N(2)\_cs in a block with combination of PUCCH formats is calculated as follow:

$N(2)_{cs} = 12 - N(1)_{cs} - 2$

This parameter can be found in 3GPP TS36.211 V8.5.0, 5.4 Physical uplink control channel.

SCPI command:

[CONFigure\[:LTE\]:UL:PUCCh:N1CS](#) on page 78

### **N(2)\_RB**

Sets bandwidth in terms of resource blocks that are reserved for PUCCH formats 2/2a/2b transmission in each subframe.

Since there can be only one resource block per slot that supports a combination of the PUCCH formats 1/1a/1b and 2/2a/2b, the number of resource block(s) per slot available for PUCCH format 1/1a/1b is determined by N(2)\_RB.

This parameter can be found in 3GPP TS36.211 V8.5.0, 5.4 Physical uplink control channel.

SCPI command:

[CONFigure\[:LTE\]:UL:PUCCh:N2RB](#) on page 78

### **Format**

Configures the physical uplink control channel format. Formats 2a and 2b are only supported for normal cyclic prefix length.

This parameter can be found in 3GPP TS36.211 V8.5.0, Table 5.4-1 Supported PUCCH formats.

SCPI command:

[CONFigure\[:LTE\]:UL:PUCCh:FORMat](#) on page 78

### **N\_PUCCH**

Sets the resource index for PUCCH format 1/1a/1b respectively 2/2a/2b.

SCPI command:

[CONFigure\[:LTE\]:UL:PUCCh:NORB](#) on page 79

## **5.2.3.5 Global Settings**

### **UE ID/n\_RNTI**

Sets the radio network temporary identifier (RNTI) of the UE.

SCPI command:

[CONFigure\[:LTE\]:UL:UEID](#) on page 84

## **5.3 Measurement Settings**

The Measurement Settings are for setting up the result displays. These settings are independent of the signal, they adjust the display of the results. You can open the dialog box via the "Meas Settings" softkey. The corresponding dialog box is made up of three



tabs. By default, the "Selection" tab is the active one. You can switch between the tabs by touching the tab on the touchscreen or with the cursor keys.

### 5.3.1 Selection

In the Selection tab you can select specific parts of the signal you want to analyze.

#### Subframe Selection

With the Subframe Selection, subframe-specific measurement results can be selected. This setting applies to the following measurements: Result Summary, EVM vs. Carrier, EVM vs. Symbol, Channel Flatness, Channel Group Delay, Channel Flatness Difference, Constellation diagram, Allocation Summary list and Bit Stream. If ---All--- is selected, either the results from all subframes are displayed at once or a statistic is calculated over all analyzed subframes.

#### Example

If you select --All--, the R&S FSVR shows the minimum / mean / maximum statistic.

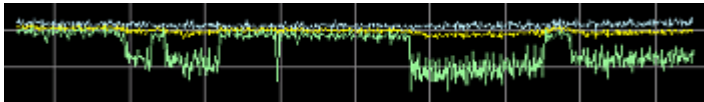

with **AV MI PK**

- PK: peak value
- AV: average value
- MI: minimum value

If you instead select a specific subframe, the R&S FSVR shows only the results of that subframe.



SCPI command:

`[SENSe] [:LTe] :SUBFrame:SElect` on page 100

### 5.3.2 Units

In the Units tab you can define the unit for various measurements.

#### EVM Unit

The EVM Unit setting allows you to display EVM results in the graphs and the numerical results in dB or %.

SCPI command:

`UNIT:EVM` on page 111

### 5.3.3 Misc

In the Misc tab you can set miscellaneous parameters.

#### Bit/Symbols Format

The Bit/Symbols Format setting allows you to display the bit stream as symbols (the bits belonging to one symbol are shown as hexadecimal numbers, always with two digits) or raw bits.

#### Examples:

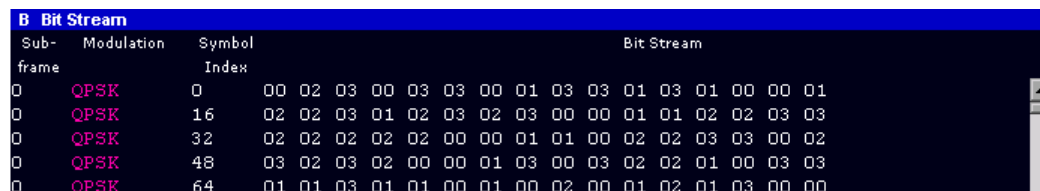

Sub-frame	Modulation	Symbol Index	Bit Stream
0	QPSK	0	00 02 03 00 03 03 00 01 03 03 01 03 01 00 00 01
0	QPSK	16	02 02 03 01 02 03 02 03 00 00 01 01 02 02 03 03
0	QPSK	32	02 02 02 02 02 00 00 01 01 00 02 02 03 03 00 02
0	QPSK	48	03 02 03 02 00 00 01 03 00 03 02 02 01 00 03 03
0	QPSK	64	01 01 03 01 01 00 01 00 02 00 01 02 01 03 00 00

Fig. 5-1: Bit stream display in uplink application if the bit stream format is set to "symbols"

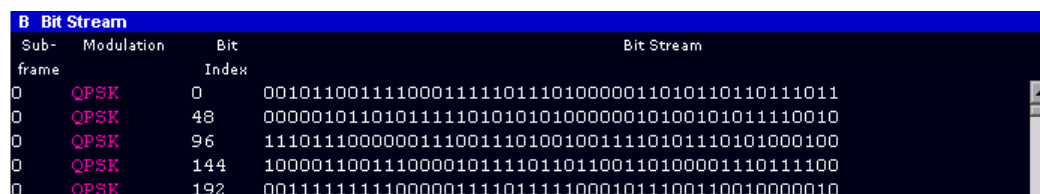

Sub-frame	Modulation	Bit Index	Bit Stream
0	QPSK	0	001011001111000111110111010000011010110110111011
0	QPSK	48	0000010110101111101010100000010100101011110010
0	QPSK	96	111011100000011100111010010011110101110101000100
0	QPSK	144	100001100111000010111101101100110100001110111100
0	QPSK	192	001111111110000011110111110001011100110010000010

Fig. 5-2: Bit stream display in uplink application if the bit stream format is set to "bits"

SCPI command:

`UNIT:BSTR` on page 110

## 5.4 ACLR Settings

The ACLR Settings are parameters for configuring the Adjacent Channel Leakage Ratio measurement.



#### Assumed Adjacent Channel Carrier

Selects the assumed adjacent channel carrier for the ACLR measurement. The supported types are EUTRA of same bandwidth, 1.28 Mcps UTRA, 3.84 Mcps UTRA and 7.68 Mcps UTRA.

Note that not all combinations of LTE Channel Bandwidth settings and Assumed Adj. Channel Carrier settings are defined in the 3GPP standard.

SCPI command:

`[SENSe]:POWer:ACHannel:AACHannel` on page 102

**Noise Correction**

Turns noise correction on and off.

For more information see the manual of the R&S FSVR.

Note that the input attenuator makes a clicking noise after every sweep if you are using the noise correction in combination with the auto leveling process.

SCPI command:

[\[SENSe\]:POWER:NCORrection](#) on page 103

## 5.5 SEM Settings

The SEM Settings are parameters for configuring the Spectrum Emission Mask measurement.

**Channel**

Selects the Category (A or B) to be used for the Spectrum Emission Mask measurement.

SCPI command:

[\[SENSe\]:POWER:SEM:CATegory](#) on page 103

## 5.6 Display and Printer Settings

The layout of the display can be controlled using the display menu. The DISP key opens the display softkey menu.

In the display menu, you can switch between split and full screen mode with the "Screen Size" softkey. In split screen mode, you can select screen A or screen B with the "Screen A" / "Screen B" hotkey. The "Screen A" / "Screen B" hotkey also toggles screen A and B in full screen mode.

The HCOPY key opens the print menu. Any open settings dialog boxes are closed when the print menu is displayed.

The print functions are the same as those provided in the base unit. Refer to the operating manual of the R&S FSVR for details on the softkey functionality.

## 6 Result Displays

This chapter provides a detailed description of all available result displays of the LTE measurement application.

Press the MEAS key to access the result display menu. There you can select the required result display by pressing the corresponding softkey.

Note that some softkeys include more than one result display. The currently selected result display is highlighted on the corresponding softkey.

### 6.1 Numerical Results

In addition to graphical result displays, the R&S FSVR also provides a table containing numerical results. You can switch between numerical and graphical results with the "Display (List Graph)" softkey.

#### Display (List Graph)

Press the Display (List Graph) softkey so that the "List" element turns green to start the Result Summary result display. This result display summarizes all relevant measurement results in one table.

Result Summary						
Frame Results	Min	Mean	Limit	Max	Limit	Unit
EVM PUSCH QPSK		0.31	17.50			%
EVM PUSCH 16QAM			12.50			%
EVM PUSCH 64QAM						%
Results for Selection	Subframe(s)	ALL	Slot(s)	ALL	Symbols meas.	140
EVM All	0.26	0.30		0.33		%
EVM Phys. Channel	0.27	0.30		0.34		%
EVM Phys. Signal	0.23	0.28		0.33		%
Frequency Error	-40.89	-39.51		-38.27		Hz
Sampling Error	-0.06	-0.03		-0.01		ppm
IQ Offset	-79.56	-77.57		-75.40		dB
IQ Gain Imbalance	-0.00	0.00		0.00		dB
IQ Quadrature Error	0.03	0.03		0.04		°
Power	-30.87	-30.87		-30.87		dBm
Crest Factor		5.87				dB

The table is split in two parts. The first part shows results that refer to the complete frame. For each result, the minimum, mean and maximum values are displayed. It also provides limit checking for result values in accordance with the selected standard. 'Pass' results are green and 'Fail' results are red.

- EVM PUSCH QPSK**  
 Shows the EVM for all QPSK-modulated resource elements of the PUSCH channel in the analyzed frame.  
[FETCh:SUMMary:EVM:USQP\[:AVERage\]](#) on page 88
- EVM PUSCH 16QAM**

Shows the EVM for all 16QAM-modulated resource elements of the PUSCH channel in the analyzed frame.

[FETCh:SUMMary:EVM:USST\[:AVERage\]](#) on page 89

- **EVM PUSCH 64QAM**

Shows the EVM for all 64QAM-modulated resource elements of the PUSCH channel in the analyzed frame.

[FETCh:SUMMary:EVM:USSF\[:AVERage\]](#) on page 89 [chapter 11.5, "FETCh Subsystem"](#), on page 85

By default, all EVM results are in %. However, you can change the EVM unit in the [EVM Unit](#) field.

The second part of the table shows results that refer to a specific selection of the frame. The header row of the second section of the table shows the selected subframe.

Note that in some cases it is not possible to measure the IQ Gain Imbalance and IQ Quadrature Error. Try to step through the subframes using the [Subframe Selection](#) to find a subframe where the measurement is available. If subframe selection is set to "All", a measurement result is available only if there are valid results in all subframes.

- **EVM All**

Shows the EVM for all resource elements in the analyzed frame.

[FETCh:SUMMary:EVM\[:ALL\]\[:AVERage\]](#) on page 88

- **EVM Phys Channel**

Shows the EVM for all physical channel resource elements in the analyzed frame.

[FETCh:SUMMary:EVM:PCHannel\[:AVERage\]](#) on page 87

- **EVM Phys Signal**

Shows the EVM for all physical signal resource elements in the analyzed frame.

[FETCh:SUMMary:EVM:PSIGNAL\[:AVERage\]](#) on page 87

- **Frequency Error**

Shows the difference in the measured center frequency and the reference center frequency.

[FETCh:SUMMary:FERRor\[:AVERage\]](#) on page 89

- **Sampling Error**

Shows the difference in measured symbol clock and reference symbol clock relative to the system sampling rate.

[FETCh:SUMMary:SERRor\[:AVERage\]](#) on page 91

- **I/Q Offset**

Shows the power at spectral line 0 normalized to the total transmitted power.

[FETCh:SUMMary:IQOffset\[:AVERage\]](#) on page 90

- **I/Q Gain Imbalance**

Shows the logarithm of the gain ratio of the Q-channel to the I-channel.

[FETCh:SUMMary:GIMBalance\[:AVERage\]](#) on page 89

- **I/Q Quadrature Error**

Shows the measure of the phase angle between Q-channel and I-channel deviating from the ideal 90 degrees.

[FETCh:SUMMary:QUADerror\[:AVERage\]](#) on page 90

- **Power**

Shows the average time domain power of the analyzed signal.

[FETCh:SUMMary:POWer\[:AVERage\]](#) on page 90

- **Crest Factor**

Shows the peak-to-average power ratio of captured signal.

[FETCh:SUMMery:CRESt\[:AVERAge\]](#) on page 87

## 6.2 Power vs Time Result Displays

This chapter contains information on LTE result displays that show the power of the signal over time.

### Capture Memory

The capture memory result display shows the complete range of captured data for the last data capture. The x-axis represents the time scale. The maximum value of the x-axis is equal to the capture length that you can set in the General Settings dialog box. The y-axis represents the amplitude of the captured I/Q data in dBm (for RF input) or V (baseband input).

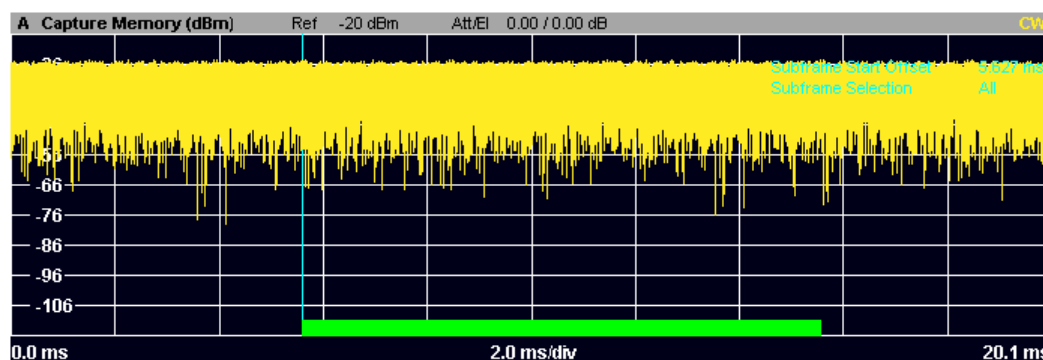
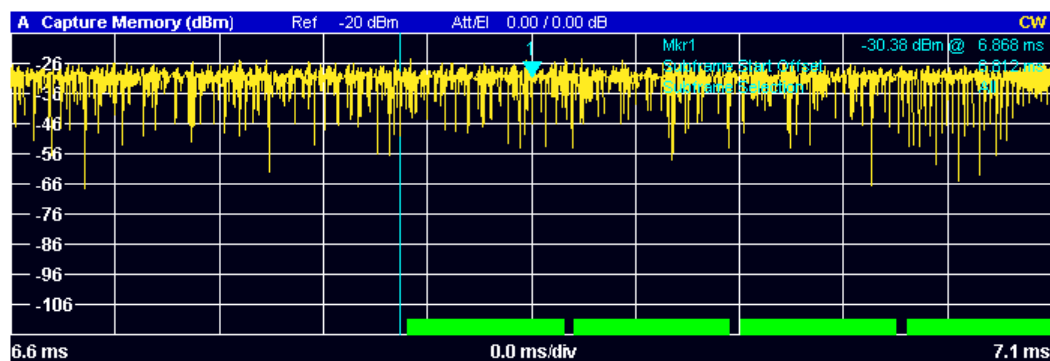

**Fig. 6-1:** Capture buffer without zoom

The header of the diagram shows the reference level, the mechanical and electrical attenuation and the trace mode.

The green bar at the bottom of the diagram represents the frame that is currently analyzed.

A blue vertical line at the beginning of the green bar in the Capture Buffer display marks the subframe start. Additionally, the graph includes the Subframe Start Offset value (blue text). This value is the time difference between the subframe start and capture buffer start.



**Fig. 6-2:** Capture buffer after a zoom has been applied

CALCulate<screenid>:FEED 'PVT:CBUF'

## 6.3 EVM Results

One of the most important results to determine the quality of a signal is the Error Vector Magnitude or EVM. Refer to [chapter 10.1, "Measurements in Detail"](#), on page 62 for details on the mathematical foundations of the EVM measurement.

The R&S FSVR EUTRA/LTE Measurement Application offers various result displays to determine the EVM of the signal on different levels.

### EVM vs Carrier

Starts the EVM vs Carrier result display.

This result display shows the Error Vector Magnitude (EVM) of the subcarriers. With the help of a marker, you can use it as a debugging technique to identify any subcarriers whose EVM is too high.

The displayed result is an average over all available OFDM symbols. By default, three traces are shown. One trace shows the average EVM. The second and the third trace show the minimum and maximum EVM values respectively. You can select to display the EVM for a specific subframe. In that case, the application shows the EVM of that subframe only.

The x-axis represents the center frequencies of the subcarriers. On the y-axis, the EVM is plotted either in % or in dB, depending on your selection in the [Measurement Settings](#) dialog box.

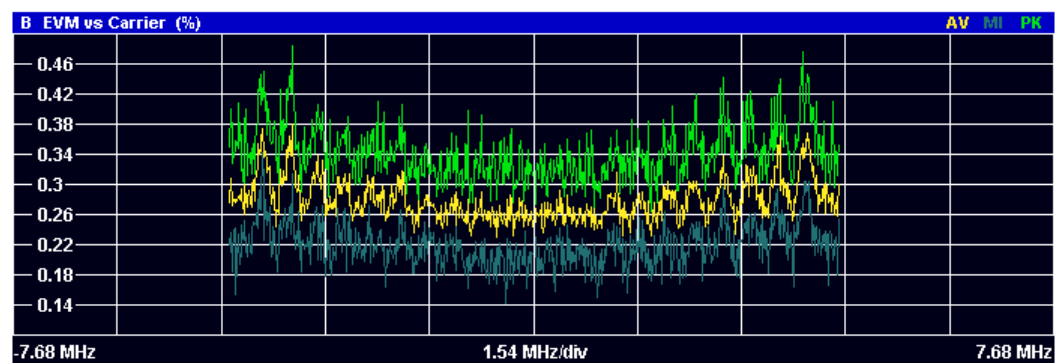

SCPI command:

CALCulate<screenid>:FEED 'EVM:EVCA'

### EVM vs Symbol

Starts the EVM vs Symbol result display.

This result display shows the Error Vector Magnitude (EVM) on symbol level. You can use it as a debugging technique to identify any symbols whose EVM is too high.

The result is an average over all subcarriers.

The x-axis represents the OFDM symbols, with each symbol represented by a dot on the line. The number of displayed symbols depends on the Subframe Selection and the length of the cyclic prefix. Any missing connections from one dot to another mean that the R&S FSVR could not determine the EVM for that symbol. On the y-axis, the EVM is plotted either in % or in dB, depending on your selection in the [Measurement Settings](#) dialog box.

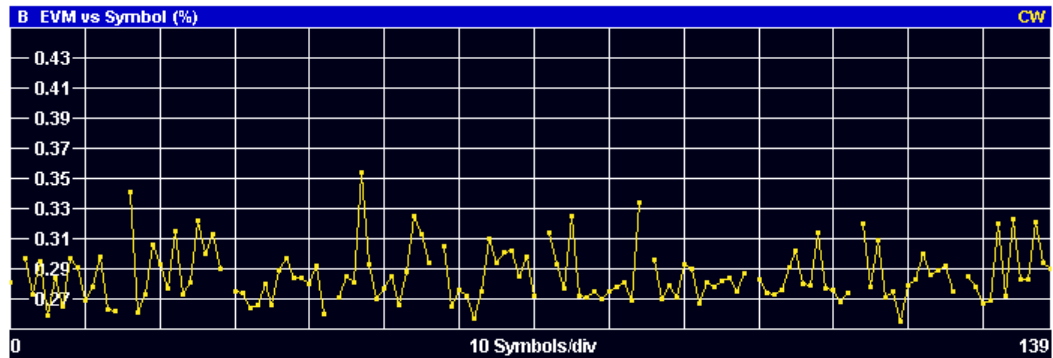

SCPI command:

`CALCulate<screenid>:FEED 'EVM:EVSU'`

#### EVM vs Subframe

Starts the EVM vs Subframe result display.

This result display shows the Error Vector Magnitude (EVM) for each subframe. You can use it as a debugging technique to identify a subframe whose EVM is too high.

The result is an average over all subcarriers and symbols of a specific subframe.

The x-axis represents the subframes, with the number of displayed subframes being 10. On the y-axis, the EVM is plotted either in % or in dB, depending on your selection in the [Measurement Settings](#) dialog box.

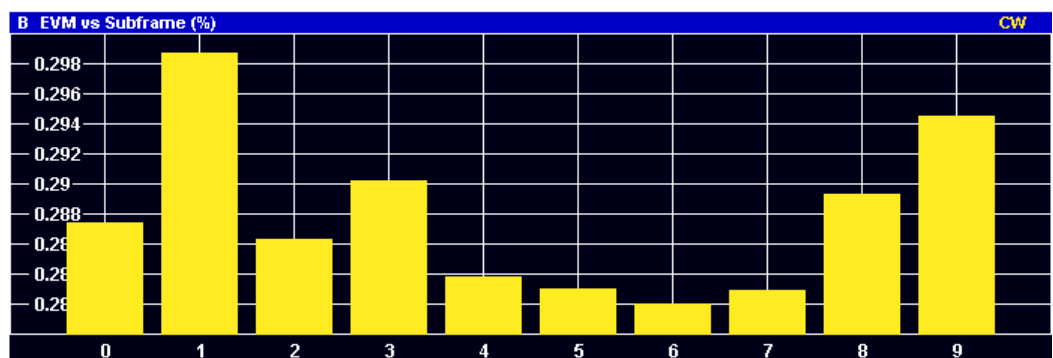

SCPI command:

`CALCulate<screenid>:FEED 'EVM:EVSU'`



## 6.4 Spectrum Measurements

This chapter contains the spectrum measurements. Spectrum measurements are separated into the frequency sweep measurements and I/Q measurements.

### 6.4.1 Frequency Sweep Measurements

The Spectrum Emission Mask (SEM) and Adjacent Channel Leakage Ratio (ACLR) measurements are the only frequency sweep measurements available with the R&S FSVR EUTRA/LTE Measurement Application. They do not use the IQ data all other measurements use. Instead those measurements sweep the frequency spectrum every time you run a new measurement. Therefore it is not possible to run an IQ measurement and then view the results in the frequency sweep measurements and vice-versa. Also because each of the frequency sweep measurement use different settings to obtain signal data it is not possible to run a frequency sweep measurement and view the results in another frequency sweep measurement.

The ACLR and SEM measurements are available if RF input is selected.

#### Spectrum Emission Mask

Starts the Spectrum Emission Mask (SEM) result display.

The Spectrum Emission Mask measurement shows the quality of the measured signal by comparing the power values in the frequency range near the carrier against a spectral mask that is defined by the 3GPP specifications. In this way, you can test the performance of the DUT and identify the emissions and their distance to the limit.

In the diagram, the SEM is represented by a red line. If any measured power levels are above that limit line, the test fails. If all power levels are inside the specified limits, the test is passed. The R&S FSVR puts a label to the limit line to indicate whether the limit check passed or failed.

The x-axis represents the frequency with a frequency span that relates to the specified EUTRA/LTE channel bandwidths. On the y-axis, the power is plotted in dBm.

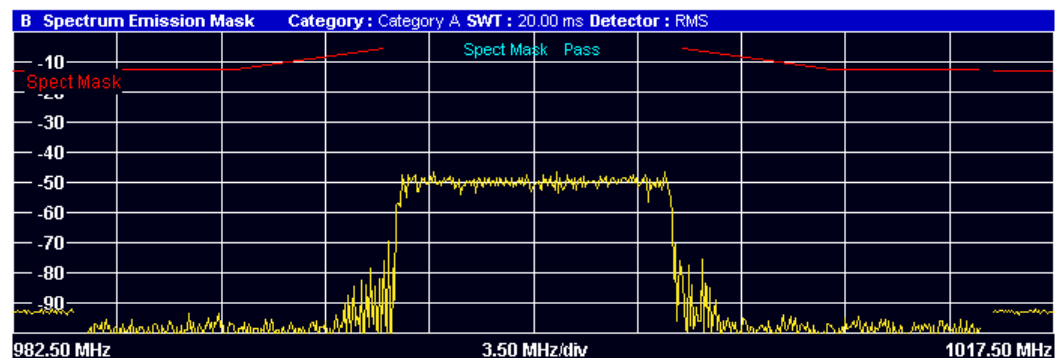

A table above the result display contains the numerical values for the limit check at each check point:

- **Start / Stop Freq Rel**  
Shows the start and stop frequency of each section of the Spectrum Mask relative to the center frequency.

- **RBW**  
Shows the resolution bandwidth of each section of the Spectrum Mask
- **Freq at  $\Delta$  to Limit**  
Shows the absolute frequency whose power measurement being closest to the limit line for the corresponding frequency segment.
- **Power Abs**  
Shows the absolute power at the frequency whose power measurement being closest to the limit line; for the corresponding frequency segment.
- **Power Rel**  
Shows the power relative to the Reference Power at the frequency closest to the limit line; for the corresponding frequency segment.
- **$\Delta$  to Limit**  
Shows the minimal distance of the tolerance limit to the SEM trace for the corresponding frequency segment. Negative distances indicate the trace is below the tolerance limit, positive distances indicate the trace is above the tolerance limit.

A Spectrum Emission Mask List						
Start Freq. Rel.	Stop Freq. Rel.	RBW	Freq. at $\Delta$ to Limit	Power Abs.	Power Rel.	$\Delta$ to Limit
-17.50 MHz	-15.50 MHz	1.00 MHz	983.453504000 MHz	-92.05 dBm	-61.65 dB	-79.05 dB
-15.05 MHz	-10.05 MHz	100.00 kHz	989.399040000 MHz	-93.46 dBm	-63.05 dB	-80.96 dB
-10.05 MHz	-5.05 MHz	100.00 kHz	994.950016000 MHz	-75.77 dBm	-45.37 dB	-70.27 dB
5.05 MHz	10.05 MHz	100.00 kHz	1.005665088 GHz	-75.44 dBm	-45.03 dB	-69.08 dB
10.05 MHz	15.05 MHz	100.00 kHz	1.010937472 GHz	-94.43 dBm	-64.03 dB	-81.93 dB
15.50 MHz	17.50 MHz	1.00 MHz	1.016883008 GHz	-92.15 dBm	-61.74 dB	-79.15 dB

SCPI command:

`CALCulate<screenid>:FEED 'SPEC:SEM'`

### ACLR

Starts the Adjacent Channel Leakage Ratio (ACLR) measurement.

The Adjacent Channel Leakage Ratio measures the power of the TX channel and the power of adjacent and alternate channels to the left and right side of the TX channel. In this way, you can get information about the power of the channels adjacent to the transmission channel and the leakage into adjacent channels.

The results show the relative power measured in the two nearest channels either side of the transmission channel.

By default the ACLR Settings are derived from the LTE Channel Bandwidth setting of the Demodulation Settings Panel. You can change the assumed adjacent channel carrier type and the noise correction via the [ACLR Settings](#).

The x-axis represents the frequency with a frequency span that relates to the specified EUTRA/LTE channel and adjacent bandwidths. On the y-axis, the power is plotted in dBm.

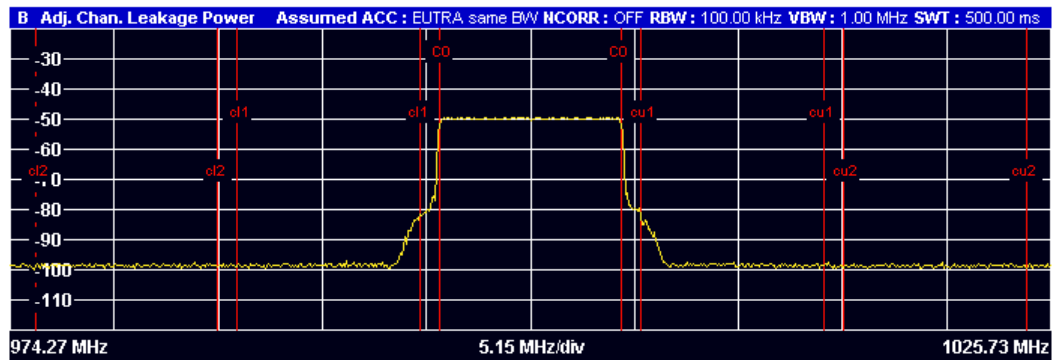

A table above the result display contains information about the measurement in numerical form:

- **Channel**  
Shows the channel type (TX, Adjacent or Alternate Channel).
- **Bandwidth**  
Shows the bandwidth of the channel.
- **Spacing**  
Shows the channel spacing.
- **Lower / Upper**  
Shows the relative power of the lower and upper adjacent and alternate channels
- **Limit**  
Shows the limit of that channel, if one is defined.

A Adj. Chan. Leakage Power Ratio List		Ref	Att/EI		Limit
Channel	Bandwidth	-26.2 dBm	0.00 / 0.00 dB		
		Spacing	Lower	Upper	
TX	9.015 MHz	...	-30.53 dB		...
Adjacent	9.015 MHz	10.00 MHz	-44.30 dB	-44.72 dB	-45.00 dB
Alternate	9.015 MHz	20.00 MHz	-48.75 dB	-48.86 dB	-45.00 dB

SCPI command:

CALCulate<screenid>:FEED 'SPEC:ACP'

### 6.4.2 I/Q Result Displays

#### Inband Emission

Starts the Inband Emission result display.

This result display shows the relative power of the unused resource blocks (yellow trace) and the inband emission limit lines (red trace) specified by the LTE standard document 3GPP TS36.10.

The measurement is evaluated over the currently selected slot in the currently selected subframe. The currently selected subframe depends on your selection in the [Measurement Settings](#) dialog box.

Note that you have to select a specific subframe and slot to get valid measurement results.

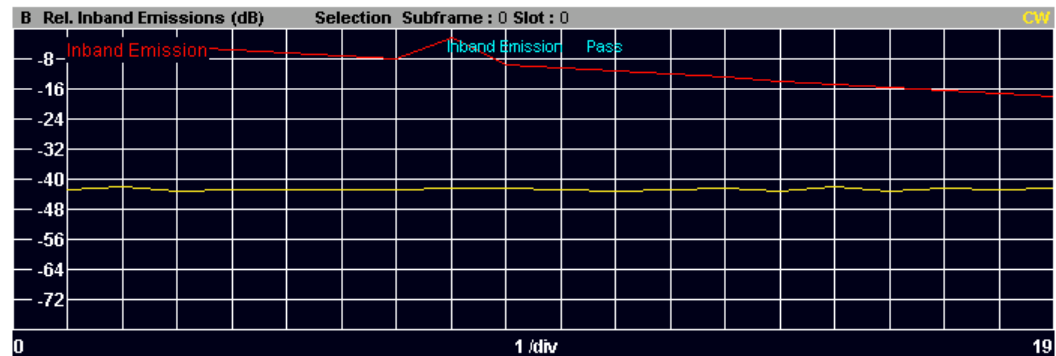

SCPI command:

`CALCulate<screenid>:FEED 'SPEC:IE'`

#### Flatness (Flat Grdel Diff)

The Flatness (Flat Grdel Diff) softkey selects one of three result displays. The currently selected result display is highlighted.

#### Channel Flatness ← Flatness (Flat Grdel Diff)

Starts the Channel Flatness result display.

This result display shows the amplitude of the channel transfer function.

The measurement is evaluated over the currently selected slot in the currently selected subframe. The currently selected subframe depends on your selection in the [Measurement Settings](#) dialog box.

The x-axis represents the frequency. On the y-axis, the power is plotted in dB.



SCPI command:

`CALCulate<screenid>:FEED 'SPEC:FLAT'`

#### Channel Group Delay ← Flatness (Flat Grdel Diff)

Starts the Channel Group Delay result display.

This result display shows the group delay of each subcarrier.

The measurement is evaluated over the currently selected slot in the currently selected subframe. The currently selected subframe depends on your selection in the [Measurement Settings](#) dialog box.

The x-axis represents the frequency. On the y-axis, the power is plotted in dB.

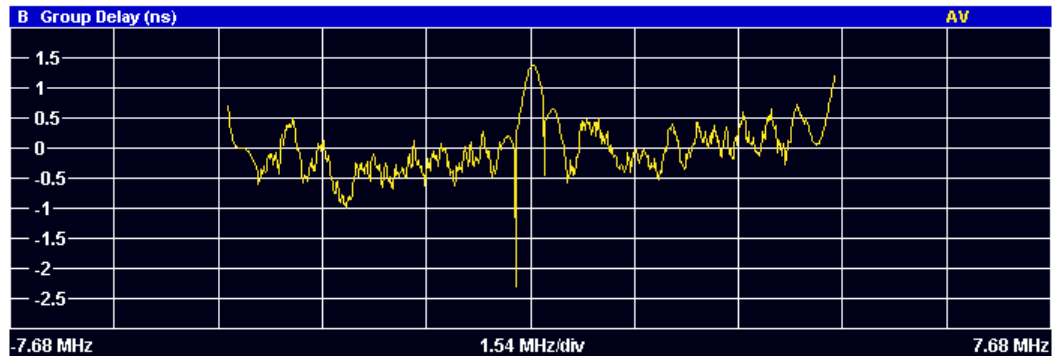

SCPI command:

`CALCulate<screenid>:FEED 'SPEC:GDEL'`

#### Channel Flatness Difference ← Flatness (Flat Grdel Diff)

Starts the Channel Flatness Difference result display.

This result display shows the level difference in the spectrum flatness result between two adjacent physical subcarriers.

The measurement is evaluated over the currently selected slot in the currently selected subframe. The currently selected subframe depends on your selection in the [Measurement Settings](#) dialog box.

The x-axis represents the frequency. On the y-axis, the power is plotted in dB.

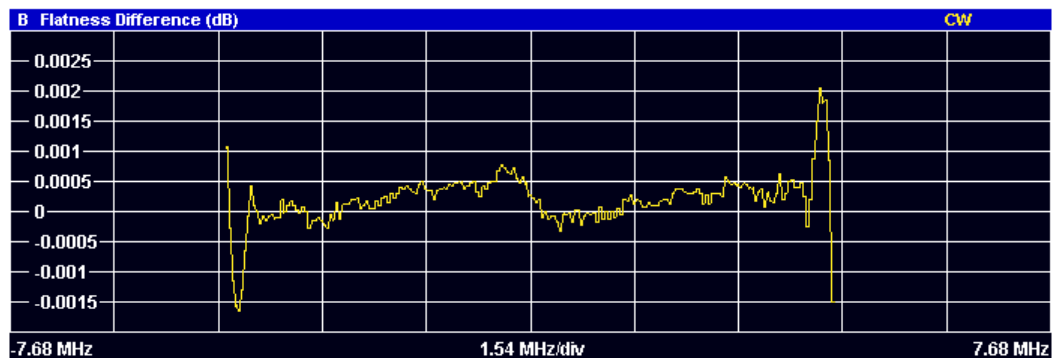

SCPI command:

`CALCulate<screenid>:FEED 'SPEC:FDIF'`

## 6.5 Constellation Diagrams

### Constellation Diagram

Starts the Constellation Diagram result display.

This result display shows the inphase and quadrature phase results and is an indicator of the quality of the modulation of the signal. The result display evaluates the full range of the measured input data. You can filter the results in the Constellation Selection dialog box.

The ideal points for the selected modulation scheme are displayed for reference purposes.

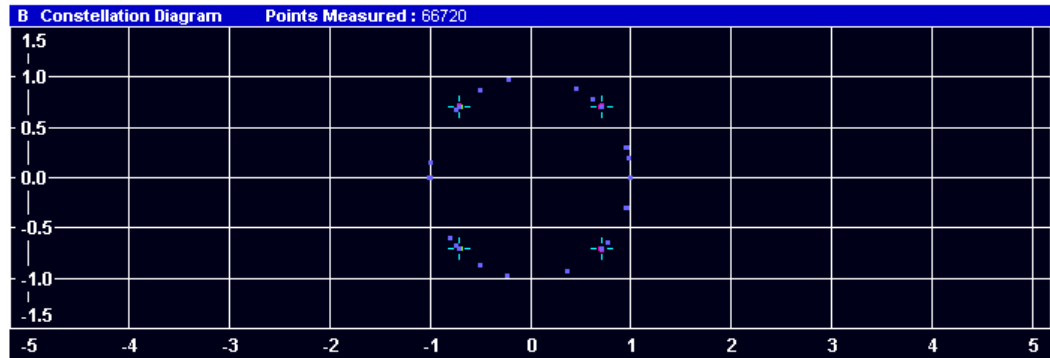

SCPI command:

`CALCulate<screenid>:FEED 'CONS:CONS'`

#### DFT Precod Constellation

Starts the DFT Precod Constellation result display.

This result display shows the inphase and quadrature phase results. It shows the data without the DFT precoding. The result display evaluates the full range of the measured input data. You can filter the results in the Constellation Selection dialog box.

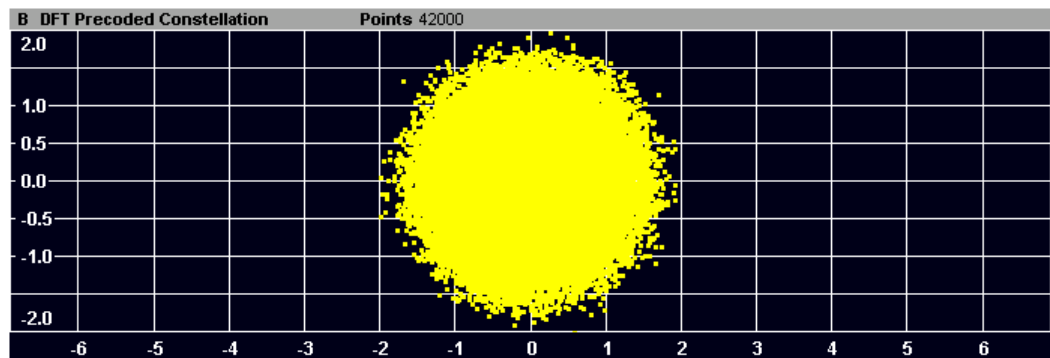

SCPI command:

`CALCulate<screenid>:FEED 'CONS:DFTC'`

#### Constellation Selection

Opens a dialog box to filter the displayed results. You can filter the results by any combination of modulation, allocation ID, symbol, carrier or location. The results are updated as soon as any change to the constellation selection parameters is made.

You can filter the results by the following parameters:

- **Modulation**  
Filter by modulation scheme.
- **Symbol**

- Filter by OFDM symbol.
- **Carrier**  
Filter by subcarrier.

## 6.6 Statistical and Miscellaneous Results

### CCDF

Starts the Complementary Cumulative Distribution Function (CCDF) result display.

This result display shows the probability of an amplitude exceeding the mean power. For the measurement, the complete capture buffer is used.

The x-axis represents the power relative to the measured mean power. On the y-axis, the probability is plotted in %.

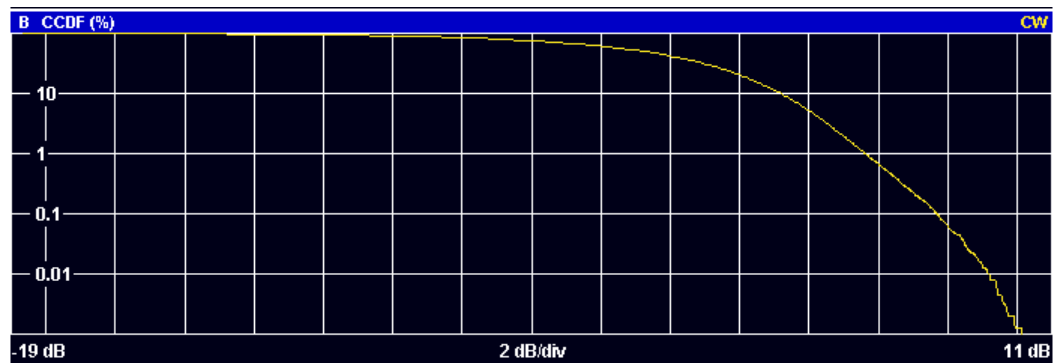

SCPI command:

`CALCulate<screenid>:FEED 'STAT:CCDF'`

### Allocation Summary

Starts the Allocation Summary result display.

This result display shows the results of the measured allocations in tabular form.

Sub-frame	Allocation ID	Number of RB	Offset RB	Modulation	Power [dBm]	EVM [%]
2	PUSCH	10	2	QPSK	-20.717	0.107
	DMRS PUSCH			CAZAC	-20.715	0.102
3	PUSCH	10	2	QPSK	-20.714	0.110
	DMRS PUSCH			CAZAC	-20.713	0.102
4	PUSCH	10	2	QPSK	-20.713	0.102
	DMRS PUSCH			CAZAC	-20.713	0.097
7	PUSCH	10	2	QPSK	-20.716	0.108
	DMRS PUSCH			CAZAC	-20.715	0.101

The rows in the table represent the allocations. A set of allocations form a subframe. The subframes are separated by a dashed line. The columns of the table contain the following information:

- **Subframe**

- Shows the subframe number.
- **Allocation ID**  
Shows the type / ID of the allocation.
- **Number of RB**  
Shows the number of resource blocks assigned to the current PDSCH allocation.
- **Offset RB**  
Shows the resource block offset of the allocation.
- **Modulation**  
Shows the modulation type.
- **Power**  
Shows the power of the allocation in dBm.
- **EVM**  
Shows the EVM of the allocation. You can change the unit of the EVM in the [Measurement Settings](#) dialog box.

SCPI command:

`CALCulate<screenid>:FEED 'STAT:ASUM'`

### Bit Stream

Starts the Bit Stream result display.

This result display shows the demodulated data stream for each data allocation. Depending on the [Bit/Symbols Format](#), the numbers represent either bits (bit order) or symbols (symbol order).

Selecting symbol format shows the bit stream as symbols. In that case the bits belonging to one symbol are shown as hexadecimal numbers with two digits. In the case of bit format, each number represents one raw bit.

B Bit Stream																		
Sub-frame	Modulation	Symbol Index	Bit Stream															
0	QPSK	0	00	02	03	00	03	03	00	01	03	03	01	03	01	00	00	01
0	QPSK	16	02	02	03	01	02	03	02	03	00	00	01	01	02	02	03	03
0	QPSK	32	02	02	02	02	02	00	00	01	01	00	02	02	03	03	00	02
0	QPSK	48	03	02	03	02	00	00	01	03	00	03	02	02	01	00	03	03
0	QPSK	64	01	01	03	01	01	00	01	00	02	00	01	02	01	03	00	00
0	QPSK	80	02	03	03	01	02	03	00	03	01	00	00	03	02	03	03	00
0	QPSK	96	00	03	03	03	03	02	00	00	03	03	01	03	03	00	01	01
0	QPSK	112	03	00	03	00	02	00	00	02	01	01	00	03	02	03	01	00
0	QPSK	128	01	03	02	01	03	03	00	03	01	02	00	02	02	02	01	00
0	QPSK	144	01	03	00	01	02	03	01	01	01	03	00	01	00	03	00	01
0	QPSK	160	00	01	00	00	00	02	00	01	00	01	02	00	01	00	03	

The table contains the following information:

- **Subframe**  
Number of the subframe the bits belong to.
- **Modulation**  
Modulation type of the channels.
- **Symbol/Bit Index**
- **Bit Stream**  
The actual bit stream.

SCPI command:

`CALCulate<screenid>:FEED 'STAT:BSTR'`



## 7 Using the Marker

The firmware application provides a marker to work with. You can use a marker to mark specific points on traces or to read out measurement results.

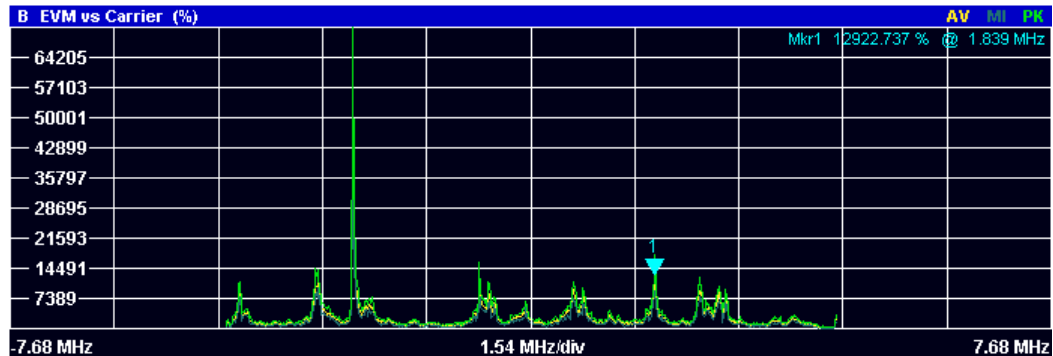

Fig. 7-1: Example: Marker

The MKR key opens the corresponding submenu. You can activate the marker with the "Marker 1" softkey. After pressing the "Marker 1" softkey, you can set the position of the marker in the marker dialog box by entering a frequency value. You can also shift the marker position by turning the rotary knob. The current marker frequency and the corresponding level is displayed in the upper right corner of the trace display.

The "Marker 1" softkey has three possible states:

If the "Marker 1" softkey is black, the marker is off.



After pressing the "Marker 1" softkey it turns orange to indicate an open dialog box and the marker is active. The dialog box to specify the marker position on the frequency axis opens.

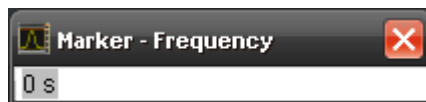

After closing the dialog box, the "Marker 1" softkey turns blue. The marker stays active.



Pressing the "Marker 1" softkey again deactivates the marker. You can also turn off the marker by pressing the "Marker Off" softkey.

If you'd like to see the area of the spectrum around the marker in more detail, you can use the Marker Zoom function. Press the "Marker Zoom" softkey to open a dialog box in which you can specify the zoom factor. The maximum possible zoom factor depends on the result display. The "Unzoom" softkey cancels the marker zoom.



Note that the zoom function is not available for all result displays.

If you have more than one active trace, it is possible to assign the marker to a specific trace. Press the "Marker -> Trace" softkey in the marker to menu and specify the trace in the corresponding dialog box.

[CALCulate<n>:MARKer<m>\[:STATe\]](#) on page 71

[CALCulate<n>:MARKer<m>:AOff](#) on page 71

[CALCulate<n>:MARKer<m>:TRACe](#) on page 72

[CALCulate<n>:MARKer<m>:X](#) on page 72

[CALCulate<n>:MARKer<m>:Y](#) on page 72

## 8 The Sweep Menu

The sweep menu contains functions that control the way the R&S FSVR performs a measurement.

### Single Sweep and Continuous Sweep

In continuous sweep mode, the R&S FSVR continuously captures data, performs measurements and updates the result display according to the trigger settings.

To activate single sweep mode, press the "Run Single" softkey. In single sweep mode, the R&S FSVR captures data, performs the measurement and updates the result display exactly once after the trigger event. After this process, the R&S FSVR interrupts the measurement.

You can always switch back to continuous sweep mode with the "Run Cont" softkey.

SCPI command:

[INITiate:CONTinuous](#) on page 92

### Auto Level

The "Auto Level" softkey initiates a process that sets an ideal reference level for the current measurement.

If you start the process while a measurement is running, the R&S FSVR aborts the measurement and starts the automatic leveling process. Measurements in continuous sweep mode are resumed after the auto level is complete.

SCPI command:

[\[SENSe\]:POWer:AUTO<analyzer>\[:STATe\]](#) on page 102

### Refresh

Updates the current result display in single sweep mode without capturing I/Q data again.

If you have changed any settings after a single sweep and use the Refresh function, the R&S FSVR updates the current measurement results with respect to the new settings. It does not capture I/Q data again but uses the data captured last.

SCPI command:

[INITiate:REFresh](#) on page 93

## 9 File Management

### 9.1 File Manager

The root menu of the application includes a File Manager with limited functions for quick access to file management functionality.

#### Loading a Frame Setup

The frame setup or frame description describes the complete modulation structure of the signal, such as bandwidth, modulation, etc.

The frame setup is stored as an XML file. XML files are very commonly used to describe hierarchical structures in an easy-to-read format for both humans and PC.

A typical frame setup file would look like this:

```
<FrameDefinition LinkDirection="uplink" TDDULDLAllocationConfiguration="0"
RessourceBlocks="50" CP="auto" PhysLayCellIDGrp="Group 0" PhysLayID="ID 0"
N_RNTI="0" N_f="0" NOfSubbands="4" N_RB_HO="4" NOfRB_PUCCH="4"
DeltaShift="2" N1_cs="6" N2_RB="1" NPUCCH="0" DeltaOffset="0"
PUCCHStructureFormat="F1 normal" N_c_fastforward="1600"
HoppingBitInformation="0" FrequencyHopping="None" DemRefSeq="3GPP"
DemPilBoostdBPU SCH="0" DemPilBoostdBPU CCH="0" GroupHop="0" SequenceHop="0"
EnableN_PR S="1" Delta_ss="0" N_DMRS1="0" N_DMRS2="0" SoundRefSeq="3GPP"
SoundRefBoostdB="0" SoundRefPresent="0" SoundRefSymOffs="13" SoundRefCAZAC_u="2"
SoundRefCAZAC_q="0" SoundRefCAZAC_alpha="0" SoundRefCAZAC_mode="2" SoundRefB="0"
SoundRefC="0" SRSSubframeConfiguration="0" SoundRefN_CS="0" SoundRefK_TC="0"
SoundRefN_RRC="0" SoundRefb_hop="0" SoundRefI_SRS="0" SoundRefk0="24"
SoundRefNumSubcarrier="132">
  <Frame>
    <Subframe>
      <PRBs>
        <PRB Start="2" Length="10" Modulation="QPSK" PUCCHOn="0" BoostingdB="0"></PRB>
      </PRBs>
    </Subframe>
  </Frame>
  <stControl PhaseTracking="1" TimingTracking="0" CompensateDCOffset="1"
    UseBitStreamScrambling="1" ChannelEstimationRange="2" AutoDemodulation="1">
  </stControl>
</FrameDefinition>
```

All settings that are available in the "Demod Settings" dialog box are also in the frame setup file. You can enter additional allocations by adding additional PRB entries in the PRBs list.

To load a frame setup, press the "File Manager" softkey in the root menu of the application. Select the file you want to load and activate it with the "Load Demod Setup" button.

### Loading an I/Q File

The R&S FSVR is able to process I/Q data that has been captured with a R&S FSVR directly as well as data stored in a file. You can store I/Q data in various file formats in order to be able to process it with other external tools or for support purposes.

I/Q data can be formatted either in binary form or as ASCII files. The data is linearly scaled using the unit Volt (e.g. if a correct display of Capture Buffer power is required). For **binary** format, data is expected as 32-bit floating point data, Little Endian format (also known as LSB Order or Intel format). An example for binary data would be: 0x1D86E7BB in hexadecimal notation is decoded to -7.0655481E-3. The order of the data is either IQIQIQ or II...IQQ...Q.

For ASCII format, data is expected as I and Q values in alternating rows, separated by new lines: <I value 1>, <Q value 1>, <I value 2>, <Q value 2>, ...

To use data that has been stored externally, press the "File Manager" softkey in the root menu of the application. Select the file you want to load and activate it with the "Load IQ Data" button.

## 9.2 SAVE/RECALL Key

Besides the file manager in the root menu, you can also manage the data via the SAVE/RECALL key.

The corresponding menu offers full functionality for saving, restoring and managing the files on the R&S FSVR. The save/recall menu is the same as that of the spectrum mode. For details on the softkeys and handling of this file manager, refer to the operating manual of the R&S FSVR.

## 10 Further Information

### 10.1 Measurements in Detail

This section provides a detailed explanation of the measurements provided by R&S FSVR-K100/-K104 and provides help for using R&S FSVR-K100/-K104 to measure the characteristics of specific types of DUT.

$a_{i,k}, \hat{a}_{i,k}$	data symbol (actual, decided)
$b_{i,k}$	boosting factor
$\Delta f, \Delta \hat{f}_{\text{coarse}}$	carrier frequency offset between transmitter and receiver (actual, coarse estimate)
$\Delta f_{\text{res}}$	residual carrier frequency offset
$\zeta$	relative sampling frequency offset
$H_{i,k}, \hat{H}_{i,k}$	channel transfer function (actual, estimate)
$i$	time index
$\hat{t}_{\text{coarse}}, \hat{t}_{\text{fine}}$	timing estimate (coarse, fine)
$k$	subcarrier index
$l$	OFDM symbol index
$N_{\text{FFT}}$	length of FFT
$N_g$	number of samples in cyclic prefix (guard interval)
$N_s$	number of Nyquist samples
$N_{\text{sc}}$	number of subcarriers
$n$	subchannel index, subframe index
$n_{i,k}$	noise sample
$\Phi_l$	common phase error
$r(i)$	received sample in the time domain
$r_{i,k}, r'_{i,k}, r''_{i,k}$	received sample (uncompensated, partially compensated, equalized) in the frequency domain
$T$	useful symbol time
$T_g$	guard time
$T_s$	symbol time

### 10.1.1 Introduction

The following description provides a brief overview of the digital signal processing used in the R&S FSVR's EUTRA/LTE measurement application. Between the received IF signal as the point of origin to the actual analysis results such as EVM, the digital signal processing can be divided into four major groups:

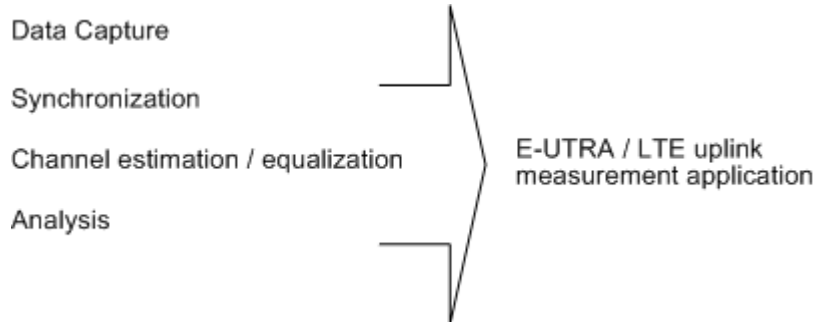

The remainder of this description is structured accordingly.

### 10.1.2 Signal Processing

#### Data Capturing

The block diagram in [figure 10-1](#) shows the R&S FSVR hardware from the IF section to the processor running the E-UTRA/LTE measurement application. The selectable IF filter bandwidth ranges from 300 kHz to 50 MHz. The A/D converter samples the IF signal at a rate of 81.6 MHz. The digital signal is converted down to the complex baseband, is lowpass-filtered, and is resampled to the nearest multiple of the target sampling rate. The decimation filters suppress the aliasing frequencies arising from the subsequent down-sampling to the target rate. Up to 16 M samples of the now available I/Q data can be stored in the capture buffer.

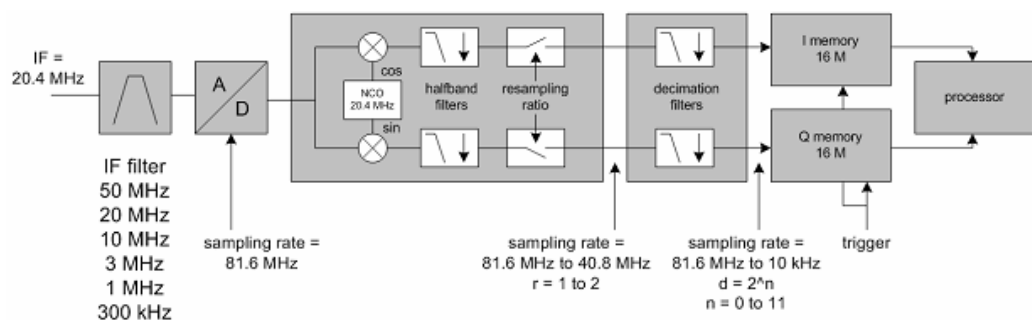

**Fig. 10-1: Data Capturing Mechanism of the R&S FSVR**

### 10.1.3 EUTRA/LTE Uplink Measurement Application

The block diagram in [figure 10-2](#) shows the general structure of the EUTRA/LTE uplink measurement application from the capture buffer containing the I/Q data up to the actual analysis block.

After synchronization a fully compensated signal is produced in the reference path (purple) which is subsequently passed to the equalizer. An IDFT of the equalized symbols yields observations for the QAM transmit symbols  $a_{n,l}$  from which the data estimates  $\hat{a}_{n,l}$  are obtained via hard decision. Likewise a user defined compensation as well as equalization is carried out in the measurement path (cyan) and after an IDFT the observations of the QAM transmit symbols  $r''_{n,l}$  are provided. Accordingly, the measurement path might still contain impairments which are compensated in the reference path. The symbols of both signal processing paths form the basis for the analysis.

#### 10.1.3.1 Synchronization

In a first step the areas of sufficient power are identified within the captured I/Q data stream which consists of the receive samples  $r_l$ . For each area of sufficient power, the analyzer synchronizes on subframes of the uplink generic frame structure [3]. After this coarse timing estimation, the fractional part as well as the integer part of the carrier frequency offset (CFO) are estimated and compensated. In order to obtain an OFDM demodulation via FFT of length  $N_{\text{FFT}}$  that is not corrupted by ISI, a fine timing is established which refines the coarse timing estimate. A phase tracking based on the reference SC-FDMA symbols is performed in the frequency domain. The corresponding tracking estimation block provides estimates for

- the relative sampling frequency offset  $\zeta$
- the residual carrier frequency offset  $\Delta f_{\text{res}}$
- the common phase error  $\Phi_l$



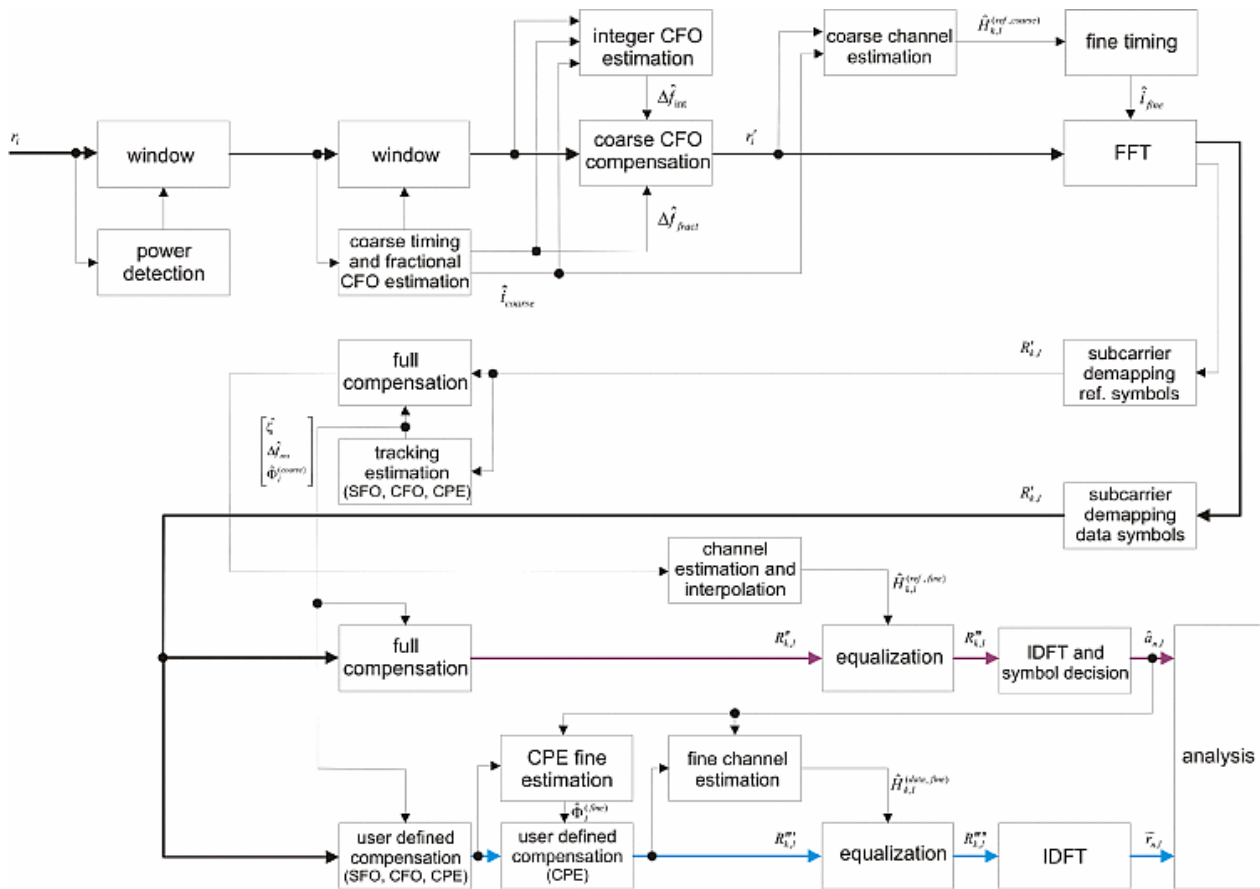

Fig. 10-2: EUTRA/LTE Downlink Measurement Application

According to references [7] and [8], the uncompensated samples  $R'_{k,l}$  in the DFT-pre-coded domain can be stated as

$$R_{l,k} = A_{l,k} \cdot H_{l,k} \cdot \underbrace{e^{j\Phi_l}}_{CPE} \cdot \underbrace{e^{j2\pi \cdot N_S / N_{FFT} \cdot \zeta \cdot k \cdot l}}_{SFO} \cdot \underbrace{e^{j2\pi \cdot N_S / N_{FFT} \cdot \Delta f_{res} \cdot T \cdot l}}_{res.CFO} + N_{l,k}$$

with

- the DFT precoded data symbol  $A_{k,l}$  on subcarrier k at SC-FDMA symbol l,
- the channel transfer function  $H_{k,l}$ ,
- the number of Nyquist samples  $N_S$  within the total duration  $T_S$ ,
- the duration of the useful part of the SC-FDMA symbol  $T = T_S - T_g$
- the independent and Gaussian distributed noise sample  $N_{k,l}$

Within one SC-FDMA symbol, both the CPE and the residual CFO cause the same phase rotation for each subcarrier, while the rotation due to the SFO depends linearly on the subcarrier index. A linear phase increase in symbol direction can be observed for the residual CFO as well as for the SFO.

The results of the tracking estimation block are used to compensate the samples  $R'_{k,l}$  completely in the reference path and according to the user settings in the measurement

path. Thus the signal impairments that are of interest to the user are left uncompensated in the measurement path.

After having decoded the data symbols in the reference path, an additional data-aided phase tracking can be utilized to refine the common phase error estimation.

### 10.1.3.2 Analysis

The analysis block of the EUTRA/LTE uplink measurement application allows you to compute a variety of measurement variables.

#### EVM

The most important variable is the error vector magnitude which is defined as

$$EVM_{l,k} = \frac{|\tilde{r}_{n,l} - \hat{a}_{n,l}|}{\sqrt{E\{|a_{n,l}|^2\}}} \quad (10 - 1)$$

for QAM symbol n before precoding and SC-FDMA symbol l. Since the normalized average power of all possible constellations is 1, [equation 10-1](#) can be simplified to

$$EVM_{n,l} = |\tilde{r}_{n,l} - \hat{a}_{n,l}|$$

The average EVM of all data subcarriers consequently results in

$$EVM_{data} = \sqrt{\frac{1}{N_{DS}N_{TX}} \sum_{l=0}^{N_{LB}-1} \sum_{n=0}^{N_{TX}-1} EVM_{n,l}^2} \quad (10 - 2)$$

for  $N_{DS}$  SC-FDMA data symbols and the  $N_{TX}$  allocated subcarriers.

#### I/Q Imbalance

The I/Q imbalance contained in the continuous received signal  $r(t)$  can be written as

$$r(t) = I \Re\{s(t)\} + jQ \Im\{s(t)\}$$

where  $s(t)$  is the transmit signal and I as well as Q are weighting factors describing the I/Q imbalance. We define that  $I:=1$  and  $Q:=1+\Delta Q$ .

The I/Q imbalance estimation makes it possible to evaluate the

$$\text{modulator gain balance} = |1 + \Delta Q|$$

and the

$$\text{quadrature mismatch} = \arg\{1 + \Delta Q\}$$

based on the complex-valued estimate  $\Delta Q$ .

### Basic In-Band Emission Measurement

The in-band emissions are a measure of the interference falling into the non-allocated resources blocks.

The relative in-band emissions are given by

$$Emissions_{relative}(\Delta_{RB}) = \frac{Emissions_{absolute}(\Delta_{RB})}{\frac{1}{|T_S| \cdot N_{RB}} \sum_{t \in T_S} \sum_c^{c+12 \cdot N_{RB}-1} |Y(t, f)|^2}$$

where  $T_S$  is a set of  $|T_S|$  SC-FDMA symbols with the considered modulation scheme being active within the measurement period,  $\Delta_{RB}$  is the starting frequency offset between the allocated RB and the measured non-allocated RB (e.g.  $\Delta_{RB}=1$  or  $\Delta_{RB}=-1$  for the first adjacent RB),  $c$  is the lower edge of the allocated BW, and  $Y(t, f)$  is the frequency domain signal evaluated for in-band emissions.  $N_{RB}$  is the number of allocated RBs .

The basic in-band emissions measurement interval is defined over one slot in the time domain.

### Other Measurement Variables

Without going into detail, the EUTRA/LTE uplink measurement application additionally provides the following results:

- Constellation diagram
- Spectral flatness
- Group delay
- I/Q offset
- I/Q imbalance
- Crest factor

## 10.2 References

- [1] 3GPP TS 25.913: Requirements for E-UTRA and E-UTRAN (Release 7)
- [2] 3GPP TR 25.892: Feasibility Study for Orthogonal Frequency Division Multiplexing (OFDM) for UTRAN enhancement (Release 6)
- [3] 3GPP TS 36.211 v8.3.0: Physical Channels and Modulation (Release 8)
- [4] 3GPP TS 36.300: E-UTRA and E-UTRAN; Overall Description; Stage 2 (Release 8)
- [5] 3GPP TS 22.978: All-IP Network (AIPN) feasibility study (Release 7)
- [6] 3GPP TS 25.213: Spreading and modulation (FDD)
- [7] Speth, M., Fechtel, S., Fock, G., and Meyr, H.: Optimum Receiver Design for Wireless Broad-Band Systems Using OFDM – Part I. IEEE Trans. on Commun. Vol. 47 (1999) No. 11, pp. 1668-1677.

[8] Speth, M., Fechtel, S., Fock, G., and Meyr, H.: Optimum Receiver Design for OFDM-Based Broadband Transmission – Part II: A Case Study. IEEE Trans. on Commun. Vol. 49 (2001) No. 4, pp. 571-578.

## 10.3 Support

If you encounter any problems when using the application, you can contact the Rohde & Schwarz support to get help for the problem.

To make the solution easier, use the "R&S Support" softkey to export useful information for troubleshooting. The R&S FSVR stores the information in a number of files that are located in the R&S FSVR directory `C:\R_S\Instr\user\LTE\Support`. If you contact Rohde&Schwarz to get help on a certain problem, send these files to the support in order to identify and solve the problem faster.

# 11 Remote Control

This section describes all the remote control commands available for the R&S FSVR EUTRA/LTE Measurement Application.

Note that this manual contains only commands that are exclusive to the firmware application. For information on remote control commands that are also available in the base unit, refer to the Operating Manual of the R&S FSVR. Also refer to the Quick Start Guide and the Operating Manual of the base unit for detailed information on working with remote control commands.

## 11.1 Numeric Suffix Definition

Some of the remote control commands that are described on the following pages have numeric suffixes in their syntax. Numeric suffixes are used if a command can be applied to multiple instances of an object, e.g. specific channels or sources, the required instances can be specified by a suffix added to the command.

Numeric suffixes are indicated by angular brackets (<1...4>, <n>, <i>) and are replaced by a single value in the command. Entries without a suffix are interpreted as having the suffix 1.

The description of the commands below does not contain the ranges and description of the suffixes. Instead, the syntax contains a variable only. When using the command, replace the variable with the numeric suffixes defined in this section.

**<n> = <1...2>**

This suffix selects the measurement screen. Possible values are <1...2> with

**1** selecting screen A and

**2** selecting screen B.

**<m> = <1>**

This suffix selects the marker. At this point, the application only supports one marker, therefore the possible range is <1>.

**<analyzer> = <1...4>**

This suffix selects the analyzer the setting applies to. Possible values are <1...4>.

**<subframe> = <0...39>**

This suffix selects the subframe that you want to analyze (see [chapter 5.2.2.3, "Configuring Subframes"](#), on page 32). Depending on your configuration, possible values are <0...9>.

**<allocation> = <0...99>**

This suffix selects the allocation that you want to analyze (see [chapter 5.2.2.3, "Configuring Subframes"](#), on page 32). Depending on your configuration, possible values are <0...99>.

## 11.2 CALCulate Subsystem

CALCulate<n>:FEED.....	70
CALCulate<n>:MARKer<m>:FUNction:POWer:RESult[:CURRent]	71
CALCulate<n>:MARKer<m>:AOFF.....	71
CALCulate<n>:MARKer<m>[:STATe]	71
CALCulate<n>:MARKer<m>:TRACe.....	72
CALCulate<n>:MARKer<m>:X.....	72
CALCulate<n>:MARKer<m>:Y.....	72

---

### CALCulate<n>:FEED <DispType>

This command selects the measurement and result display.

#### Parameters:

<DispType>	String containing the short form of the result display.
'EVM:EVCA' (EVM vs carrier result display)	
'EVM:EVSY' (EVM vs symbol result display)	
'EVM:FEVS' (frequency error vs symbol result display)	
'EVM:EVSU' (EVM vs subframe result display)	
'PVT:CBUF' (capture buffer result display)	
'SPEC:SEM' (spectrum emission mask)	
'SPEC:ACP' (ACLR)	
'SPEC:PSPE' (power spectrum result display)	
'SPEC:FLAT' (spectrum flatness result display)	
'SPEC:GDEL' (group delay result display)	
'SPEC:FDIF' (flatness difference result display)	
SPEC:IE (inband emission result display: uplink only)	
'CONS:CONS' (constellation diagram)	
CONS:DFTC (DFT precoded constellation diagram: uplink only)	
'STAT:BSTR' (bitstream)	
'STAT:ASUM' (allocation summary)	
'STAT:CCDF' (CCDF)	

#### Example:

```
CALC2:FEED 'PVT:CBUF'
```

Select Capture Buffer to be displayed on screen B.

**CALCulate<n>:MARKer<m>:FUNCtion:POWer:RESult[:CURRent]?**

This command queries the current results of the ACLR measurement.

To get a valid result, you have to perform a complete measurement with synchronization to the end of the measurement before reading out the result. This is only possible for single sweeps.

**Suffix:**

<m> 1

**Return values:**

<ACPRResults> The number of return values depends on the number of transmission and adjacent channels. The order of return values is:

- <TXChannelPower> is the power of the transmission channel in dBm
- <LowerAdjChannelPower> is the relative power of the lower adjacent channel in dB
- <UpperAdjChannelPower> is the relative power of the upper adjacent channel in dB
- <1stLowerAltChannelPower> is the relative power of the first lower alternate channel in dB
- <1stUpperAltChannelPower> is the relative power of the first lower alternate channel in dB
- (...)
- <nLowerAltChannelPower> is the relative power of a subsequent lower alternate channel in dB
- <nLowerAltChannelPower> is the relative power of a subsequent lower alternate channel in dB

**Example:**

CALC1:MARK:FUNC:POW:RES?

Returns the current ACLR measurement results.

**Usage:**

Query only

**CALCulate<n>:MARKer<m>:AOFF**

This command turns all markers and delta markers off.

**Example:**

CALC:MARK:AOFF

Switches off all markers.

**Usage:**

Event

**CALCulate<n>:MARKer<m>[:STATe] <State>**

This command turns markers on and off. If the corresponding marker number is currently active as a deltamarker, it is turned into a normal marker.

**Parameters:**

<State> ON | OFF  
\*RST: OFF

**Example:**            `CALC:MARK3 ON`  
Switches on marker 3.

---

### **CALCulate<n>:MARKer<m>:TRACe <Trace>**

This command selects the trace the marker is positioned on.

Note that the corresponding trace must have a trace mode other than "Blank".

If necessary, the command activates the marker first.

**Parameters:**

<Trace>                **1 to 6**  
Trace number the marker is assigned to.

**Example:**            `CALC:MARK3:TRAC 2`  
Assigns marker 3 to trace 2.

---

### **CALCulate<n>:MARKer<m>:X <Position>**

This command moves a marker to a particular coordinate on the x-axis.

If necessary, the command activates the marker.

If the marker has been used as a delta marker, the command turns it into a normal marker.

**Parameters:**

<Position>            Numeric value that defines the marker position on the x-axis.  
Range:                The range depends on the current x-axis range.

**Example:**            `CALC:MARK2:X 1.7MHz`  
Positions marker 2 to frequency 1.7 MHz.

---

### **CALCulate<n>:MARKer<m>:Y?**

This command queries the position of a marker on the y-axis.

If necessary, the command activates the marker first.

To get a valid result, you have to perform a complete measurement with synchronization to the end of the measurement before reading out the result. This is only possible for single sweeps.

**Return values:**

<Result>               Position of the marker.

**Example:**            `INIT:CONT OFF`  
Switches to single measurement mode.  
`CALC:MARK2 ON`  
Switches marker 2.  
`INIT;*WAI`  
Starts a measurement and waits for the end.  
`CALC:MARK2:Y?`  
Outputs the measured value of marker 2.



**Usage:** Query only

## 11.3 CONFigure Subsystem

CONFigure[:LTE]:DL:PLC:CIDGroup.....	74
CONFigure[:LTE]:DUPLexing.....	74
CONFigure[:LTE]:LDIRecton.....	74
CONFigure[:LTE]:UL:BW.....	74
CONFigure[:LTE]:UL:CSUBframes.....	75
CONFigure[:LTE]:UL:CYCPrefix.....	75
CONFigure[:LTE]:UL:DRS:DSSHift.....	75
CONFigure[:LTE]:UL:DRS:ENPR.....	75
CONFigure[:LTE]:UL:DRS:GRPHopping.....	76
CONFigure[:LTE]:UL:DRS:PUCCh:POWer.....	76
CONFigure[:LTE]:UL:DRS:SEQHopping.....	76
CONFigure[:LTE]:UL:DRS[:PUSCh]:POWer.....	76
CONFigure[:LTE]:UL:NORB.....	77
CONFigure[:LTE]:UL:PLC:CIDGroup.....	77
CONFigure[:LTE]:UL:PLC:PLID.....	77
CONFigure[:LTE]:UL:PUCCh:DEOffset.....	77
CONFigure[:LTE]:UL:PUCCh:DESHift.....	78
CONFigure[:LTE]:UL:PUCCh:FORMat.....	78
CONFigure[:LTE]:UL:PUCCh:N1CS.....	78
CONFigure[:LTE]:UL:PUCCh:N2RB.....	78
CONFigure[:LTE]:UL:PUCCh:NORB.....	79
CONFigure[:LTE]:UL:PUSCh:FHMode.....	79
CONFigure[:LTE]:UL:PUSCh:FHOFset.....	79
CONFigure[:LTE]:UL:PUSCh:FHOP:IIHB.....	79
CONFigure[:LTE]:UL:PUSCh:NOSM.....	80
CONFigure[:LTE]:UL:SFNO.....	80
CONFigure[:LTE]:UL:SRS:BHOP.....	80
CONFigure[:LTE]:UL:SRS:BSRS.....	80
CONFigure[:LTE]:UL:SRS:CSRS.....	81
CONFigure[:LTE]:UL:SRS:CYCS.....	81
CONFigure[:LTE]:UL:SRS:ISRS.....	81
CONFigure[:LTE]:UL:SRS:NRRC.....	81
CONFigure[:LTE]:UL:SRS:POWer.....	82
CONFigure[:LTE]:UL:SRS:STAT.....	82
CONFigure[:LTE]:UL:SRS:SUConfig.....	82
CONFigure[:LTE]:UL:SRS:TRComb.....	82
CONFigure[:LTE]:UL:SUBFrame<subframe>:ALLoc:CONT.....	82
CONFigure[:LTE]:UL:SUBFrame<subframe>:ALLoc:MODulation.....	83
CONFigure[:LTE]:UL:SUBFrame<subframe>:ALLoc:POWer.....	83
CONFigure[:LTE]:UL:SUBFrame<subframe>:ALLoc:RBCount.....	83
CONFigure[:LTE]:UL:SUBFrame<subframe>:ALLoc:RBOFset.....	84
CONFigure[:LTE]:UL:TDD:UDConf.....	84
CONFigure[:LTE]:UL:UEID.....	84
CONFigure:POWer:EXPeCted:IQ<analyzer>.....	84

CONFigure:POWer:EXPected:RF<analyzer>.....84

---

### CONFigure[:LTE]:DL:PLC:CIDGroup <GroupNumber>

This command selects the cell ID group for downlink signals.

#### Parameters:

<GroupNumber>      AUTO | <numeric value>  
**AUTO**  
 Automatic selection  
**0...167**  
 Manual selection  
 \*RST:      AUTO

#### Example:

```
CONF:DL:PLC:CIDG 134
Cell identity group number 134 is selected
CONF:DL:PLC:CIDG AUTO
Automatic cell identity group detection is selected
```

---

### CONFigure[:LTE]:DUPLexing <Duplexing>

This command selects the duplexing mode.

#### Parameters:

<Duplexing>      **TDD**  
 Time division duplex  
**FDD**  
 Frequency division duplex  
 \*RST:      FDD

#### Example:

```
CONF:DUPL TDD
Activates time division duplex.
```

---

### CONFigure[:LTE]:LDIRection <Direction>

This command selects the link direction

#### Parameters:

<Direction>      **DL**  
 Downlink  
**UL**  
 Uplink

#### Example:

```
CONF:LDIR DL
EUTRA/LTE option is configured to analyze downlink signals.
```

---

### CONFigure[:LTE]:UL:BW <Bandwidth>

This command selects the uplink bandwidth.

**Parameters:**

<Bandwidth> BW1\_40 | BW3\_00 | BW5\_00 | BW10\_00 | BW15\_00 |  
BW20\_00

**Example:**

```
CONF:UL:BW BW1_40
```

Sets a signal bandwidth of 1.4 MHz in uplink.

**CONFigure[LTE]:UL:CSUBframes <NofSubframes>**

This command selects the number of configurable subframes in the uplink signal.

**Parameters:**

<NofSubframes> Range: 0 to 9  
\*RST: 1

**Example:**

```
CONF:UL:CSUB 5
```

Sets the number of configurable subframes to 5.

**CONFigure[LTE]:UL:CYCPrefix <PrefixLength>**

This command selects the cyclic prefix for uplink signals.

**Parameters:**

<PrefixLength> **NORM**  
Normal cyclic prefix length  
**EXT**  
Extended cyclic prefix length  
**AUTO**  
Automatic cyclic prefix length detection  
\*RST: AUTO

**Example:**

```
CONF:UL:CYCP EXT
```

Sets cyclic prefix type to extended.

**CONFigure[LTE]:UL:DRS:DSSHift <Shift>**

This command selects the delta sequence shift of the uplink signal.

**Parameters:**

<Shift> <numeric value>  
\*RST: 0

**Example:**

```
CONF:UL:DRS:DSSH 3
```

Sets the delta sequence shift to 3.

**CONFigure[LTE]:UL:DRS:ENPR <State>**

This command turns the nPRS in the demodulation RS configuration of uplink signals on and off.

**Parameters:**

<State> ON | OFF  
 \*RST: ON

**Example:**

CONF:UL:DRS:ENPR ON  
 Activates n\_PRs.

**CONFigure[:LTE]:UL:DRS:GRPHopping <State>**

This command turns group hopping for uplink signals on and off.

**Parameters:**

<State> ON | OFF  
 \*RST: OFF

**Example:**

CONF:UL:DRS:GRPHopping ON  
 Activates group hopping.

**CONFigure[:LTE]:UL:DRS:PUCCh:POWer <Power>**

This command sets the relative power of the PUCCH.

**Parameters:**

<Power> \*RST: 0  
 Default unit: DB

**Example:**

CONF:UL:DRS:PUCc:POW 2  
 Sets the power of the PUCCH to 2 dB.

**CONFigure[:LTE]:UL:DRS:SEQHopping <State>**

This command turns sequence hopping for uplink signals on and off.

**Parameters:**

<State> ON | OFF  
 \*RST: OFF

**Example:**

CONF:UL:DRS:SEQH ON  
 Activates sequence hopping.

**CONFigure[:LTE]:UL:DRS[:PUSCh]:POWer <Power>**

This command sets the relative power of the PUSCH.

**Parameters:**

<Power> \*RST: 0  
 Default unit: DB

**Example:**

CONF:UL:DRS:POW 2  
 Sets the relative power of the PUSCH to 2 dB.

**CONFigure[:LTE]:UL:NORB** <ResourceBlocks>

This command selects the number of resource blocks for uplink signals.

**Parameters:**

<ResourceBlocks> <numeric value>  
\*RST: 50

**Example:**

CONF:UL:NORB 25  
Sets the number of resource blocks to 25.

**CONFigure[:LTE]:UL:PLC:CIDGroup** <GroupNumber>

This command selects the cell identity group for uplink signals.

**Parameters:**

<GroupNumber> <numeric value>  
Range: 1 to 167  
\*RST: 0

**Example:**

CONF:UL:PLC:CIDG 12  
Selects cell identity group 12.

**CONFigure[:LTE]:UL:PLC:PLID** <Identity>

This command selects the physical layer identity for uplink signals.

**Parameters:**

<Identity> AUTO | <numeric value>  
**AUTO**  
Automatic selection  
**0...2**  
Manual selection  
\*RST: AUTO

**Example:**

CONF:DL:PLC:PLID 2  
Sets the physical layer identity to 2.  
CONF:DL:PLC:PLID AUTO  
Physical layer ID is selected automatically.

**CONFigure[:LTE]:UL:PUCCh:DEOffset** <Offset>

This command defines the delta offset of the PUCCH.

**Parameters:**

<Offset> <numeric value>  
Range: 0 to 2  
\*RST: 0

**Example:**

CONF:UL:PUCCh:DEOF 2  
Sets the delta offset to 2.

---

**CONFigure[:LTE]:UL:PUCCh:DESHift <Shift>**

This command defines the delta shift of the PUCCH.

**Parameters:**

<Shift>                    <numeric value>  
 Range:            1 to 3  
 \*RST:            2

**Example:**

CONF:UL:PUCCh:DESH 3  
 Sets the delta shift of the PUCCH to 3.

---

**CONFigure[:LTE]:UL:PUCCh:FORMat <Format>**

This command selects the PUCCH format.

Note that formats 2a and 2b are available for normal cyclic prefix length only.

**Parameters:**

<Format>                    **F1N (F1 normal)**  
                                  **F1S (F1 shortened)**  
                                  **F1AN (F1a normal)**  
                                  **F1AS (F1a shortened)**  
                                  **F1BN (F1b normal)**  
                                  **F1BS (F1b shortened)**  
                                  **F2 (F2)**  
                                  **F2A (F2a)**  
                                  **F2B (F2b)**  
 \*RST:            F1N

**Example:**

CONF:UL:PUCCh:FORM F1N  
 Sets the PUCCH format to F1 normal.

---

**CONFigure[:LTE]:UL:PUCCh:N1CS <N1cs>**

This command defines the N(1)\_cs of the PUCCH.

**Parameters:**

<N1cs>                    <numeric value>  
 \*RST:            6

**Example:**

CONF:UL:PUCCh:N1CS 4  
 Sets N(1)\_cs to 4.

---

**CONFigure[:LTE]:UL:PUCCh:N2RB <N2RB>**

This command defines the N(2)\_RB of the PUCCH.

**Parameters:**

<N2RB> <numeric value>  
 \*RST: 1

**Example:**

CONF:UL:PUC:N2RB 2  
 Sets N2\_RB to 2.

**CONFigure[:LTE]:UL:PUCCh:NORB** <ResourceBlocks>

This command selects the number of resource blocks for the PUCCH.

**Parameters:**

<ResourceBlocks> <numeric value>  
 \*RST: 0

**Example:**

CONF:UL:PUC:NORB 6  
 Sets the number of resource blocks to 6.

**CONFigure[:LTE]:UL:PUSCh:FHMode** <HoppingMode>

This command selects the frequency hopping mode in the PUSCH structure.

**Parameters:**

<HoppingMode> **NONE**  
 No hopping  
**INTer**  
 Inter subframe hopping  
**INTRa**  
 Intra subframe hopping  
 \*RST: NONE

**Example:**

CONF:UL:PUSC:FHM NONE  
 Deactivates frequency hopping for the PUSCH.

**CONFigure[:LTE]:UL:PUSCh:FHOOffset** <Offset>

This command defines the frequency hopping offset for the PUSCH.

**Parameters:**

<Offset> <numeric value>  
 \*RST: 4

**Example:**

CONF:UL:PUSC:FHO 5  
 Sets the hopping offset to 5.

**CONFigure[:LTE]:UL:PUSCh:FHOP:IIHB** <HBInfo>

This command defines the information in hopping bits of the PUSCH.

**Parameters:**

<HBInfo> <numeric value>  
 Range: 0 to 3  
 \*RST: 0

**Example:**

CONF:UL:PUSC:FHOP:IIHB 1  
 Defines type 1 as the information in hopping bits.

**CONFigure[:LTE]:UL:PUSCh:NOSM <NofSubbands>**

This command defines the number of subbands/M of the PUSCH.

**Parameters:**

<NofSubbands> <numeric value>  
 \*RST: 4

**Example:**

CONF:UL:PUSC:NOSM 2  
 Sets the number of subbands to 2.

**CONFigure[:LTE]:UL:SFNO <Offset>**

This command defines the system frame number offset.

The application uses the offset to demodulate the frame.

**Parameters:**

<Offset> <numeric value>  
 \*RST: 0

**Example:**

CONF:UL:SFNO 2  
 Selects frame number offset 2.

**CONFigure[:LTE]:UL:SRS:BHOP <Bandwidth>**

This command defines the frequency hopping bandwidth  $b_{\text{hop}}$ .

**Parameters:**

<Bandwidth> <numeric value>  
 \*RST: 0

**Example:**

CONF:UL:SRS:BHOP 1  
 Sets the frequency hopping bandwidth to 1.

**CONFigure[:LTE]:UL:SRS:BSRS <Bandwidth>**

This command defines the bandwidth of the SRS ( $B_{\text{SRS}}$ ).

**Parameters:**

<Bandwidth> <numeric value>  
 \*RST: 0



**Example:**            `CONF:UL:SRS:BSRS 1`  
Sets the SRS bandwidth to 1.

---

#### **CONFigure[:LTE]:UL:SRS:CSRS <Configuration>**

This command defines the SRS bandwidth configuration ( $C_{SRS}$ ).

**Parameters:**  
 <Configuration>        <numeric value>  
                               \*RST:        0

**Example:**            `CONF:UL:SRS:CSRS 2`  
Sets the SRS bandwidth configuration to 2.

---

#### **CONFigure[:LTE]:UL:SRS:CYCS <CyclicShift>**

Sets the cyclic shift  $n_{CS}$  used for the generation of the sounding reference signal CAZAC sequence.

**Parameters:**  
 <CyclicShift>            <numeric value>  
                               \*RST:        0

**Example:**            `CONF:UL:SRS:CYCS 2`  
Sets the cyclic shift to 2.

---

#### **CONFigure[:LTE]:UL:SRS:ISRS <ConfIndex>**

This command defines the SRS configuration index ( $I_{SRS}$ ).

**Parameters:**  
 <ConfIndex>            <numeric value>  
                               \*RST:        0

**Example:**            `CONF:UL:SRS:ISRS 1`  
Sets the configuration index to 1.

---

#### **CONFigure[:LTE]:UL:SRS:NRRC <FreqDomPos>**

Sets the UE specific parameter Freq. Domain Position  $n_{RRC}$ .

**Parameters:**  
 <FreqDomPos>            <numeric value>  
                               \*RST:        0

**Example:**            `CONF:UL:SRS:NRRC 1`  
Sets  $n_{RRC}$  to 1.

---

**CONFigure[:LTE]:UL:SRS:POWer** <Power>

Defines the relative power of the sounding reference signal.

**Parameters:**

<Power>                    <numeric value>  
\*RST:                    0  
Default unit: DB

**Example:**                    CONF:UL:SRS:POW -1.2  
Sets the power to -1.2 dB.

---

**CONFigure[:LTE]:UL:SRS:STAT** <State>

Activates or deactivates the sounding reference signal.

**Parameters:**

<State>                    ON | OFF  
\*RST:                    OFF

**Example:**                    CONF:UL:SRS:STAT ON  
Activates the sounding reference signal.

---

**CONFigure[:LTE]:UL:SRS:SUConfig** <Configuration>

This command defines the SRS subframe configuration.

**Parameters:**

<Configuration>            <numeric value>  
\*RST:                    0

**Example:**                    CONF:UL:SRS:SUC 4  
Sets SRS subframe configuration to 4.

---

**CONFigure[:LTE]:UL:SRS:TRComb** <TransComb>

This command defines the transmission comb ( $k_{TC}$ ).

**Parameters:**

<TransComb>                <numeric value>  
\*RST:                    0

**Example:**                    CONF:UL:SRS:TRC 1  
Sets transmission comb to 1.

---

**CONFigure[:LTE]:UL:SUBFrame<subframe>:ALLoc:CONT** <Content>

This command allocates a PUCCH or PUSCH to an uplink allocation.

**Parameters:**

&lt;Content&gt;

**NONE**

Turns off the PUSCH and the PUCCH.

**PUCCh**

Turns on the PUCCH.

**PUSCh**

Turns on the PUSCH.

**PSCC**

Turns on the PUCCH as well as the PUSCH.

**\*RST:** PUSC**Example:**`CONF:UL:SUBF8:ALL:CONT PUCc`

Subframe 8 contains a PUCCH.

**CONFigure[LTE]:UL:SUBFrame<subframe>:ALLoc:MODulation <Modulation>**

This command selects the modulation of an uplink allocation.

**Parameters:**

&lt;Modulation&gt;

QPSK | QAM16 | QAM64

**\*RST:** QPSK**Example:**`CONF:UL:SUBF8:ALL:MOD QPSK`

The modulation of the allocation in subframe 8 is QPSK.

**CONFigure[LTE]:UL:SUBFrame<subframe>:ALLoc:POWER <Power>**

This command defines the (relative) power of an uplink allocation.

**Parameters:**

&lt;Power&gt;

&lt;numeric value&gt;

**\*RST:** 0

Default unit: DB

**Example:**`CONF:UL:SUBF8:ALL:POW -1.3`

Sets the power of the allocation in subframe 8 to -1.3 dB.

**CONFigure[LTE]:UL:SUBFrame<subframe>:ALLoc:RBCCount <NofRBs>**

This command selects the number of resource blocks in an uplink subframe.

**Parameters:**

&lt;NofRBs&gt;

&lt;numeric value&gt;

**\*RST:** 11**Example:**`CONF:UL:SUBF8:ALL:RBC 8`

Subframe 8 consists of 8 resource blocks.

**CONFigure[:LTE]:UL:SUBFrame<subframe>:ALLoc:RBOffset <RBOffset>**

This command defines the resource block offset in an uplink subframe.

**Parameters:**

<RBOffset>            <numeric value>  
                          \*RST:        2

**Example:**

CONF:UL:SUBF8:ALL:RBOF 5  
 Subframe 8 has a resource block offset of 5.

**CONFigure[:LTE]:UL:TDD:UDConf <Configuration>**

This command selects the UL/DL TDD subframe configuration for uplink signals.

**Parameters:**

<Configuration>      Range:        0 to 6  
                          \*RST:        0

**Example:**

CONF:UL:TDD:UDC 4  
 Selects allocation configuration number 4.

**CONFigure[:LTE]:UL:UEID <ID>**

Sets the radio network temporary identifier (RNTI) of the UE.

**Parameters:**

<ID>                    <numeric value>  
                          \*RST:        0

**Example:**

CONF:UL:UEID 2  
 Sets the UE ID to 2.

**CONFigure:POWer:EXPEcted:IQ<analyzer> <RefLevel>**

This command defines the reference level when the input source is baseband.

**Parameters:**

<RefLevel>            <numeric value>  
                          Range:        31.6 mV to 5.62 V  
                          \*RST:        1 V  
                          Default unit: V

**Example:**

CONF:POW:EXP:IQ2 3.61  
 Sets the baseband-reference level used by analyzer 2 to 3.61 V.

**CONFigure:POWer:EXPEcted:RF<analyzer> <RefLevel>**

This command defines the reference level when the input source is RF.

**Parameters:**

<RefLevel>                    \*RST:        -30 dBm  
                                   Default unit: DBM

**Example:**

CONF:POW:EXP:RF3 -20  
 Sets the radio frequency reference level used by analyzer 3 to -20 dBm.

## 11.4 DISPlay Subsystem

DISPlay[:WINDow<n>]:SElect.....	85
DISPlay[:WINDow<n>]:TRACe<t>:Y[:SCALe]:RLEVel:OFFSet.....	85

---

### DISPlay[:WINDow<n>]:SElect

This command selects the measurement window.

**Example:**                    DISP:WIND2:SEL  
                                   Selects screen B.

**Usage:**                      Event

---

### DISPlay[:WINDow<n>]:TRACe<t>:Y[:SCALe]:RLEVel:OFFSet <Attenuation>

This command selects the external attenuation or gain applied to the RF signal.

**Parameters:**

<Attenuation>                <numeric value>  
                                   \*RST:        0  
                                   Default unit: dB

**Example:**                    DISP:TRAC:Y:RLEV:OFFS 10  
                                   Sets an external attenuation of 10 dB.

## 11.5 FETCh Subsystem

FETCh:CYCPrefix.....	86
FETCh:PLCI:CIDGroup.....	86
FETCh:PLCI:PLID.....	87
FETCh:SUMMary:CRESt[:AVERAge].....	87
FETCh:SUMMary:EVM:PCHannel:MAXimum.....	87
FETCh:SUMMary:EVM:PCHannel:MINimum.....	87
FETCh:SUMMary:EVM:PCHannel[:AVERAge].....	87
FETCh:SUMMary:EVM:PSIGnal:MAXimum.....	87
FETCh:SUMMary:EVM:PSIGnal:MINimum.....	87
FETCh:SUMMary:EVM:PSIGnal[:AVERAge].....	87
FETCh:SUMMary:EVM[:ALL]:MAXimum.....	88
FETCh:SUMMary:EVM[:ALL]:MINimum.....	88

FETCh:SUMMary:EVM[:ALL][:AVERage].....	88
FETCh:SUMMary:EVM:USQP[:AVERage].....	88
FETCh:SUMMary:EVM:USSF[:AVERage].....	89
FETCh:SUMMary:EVM:USST[:AVERage].....	89
FETCh:SUMMary:FERRor:MAXimum.....	89
FETCh:SUMMary:FERRor:MINimum.....	89
FETCh:SUMMary:FERRor[:AVERage].....	89
FETCh:SUMMary:GIMBalance:MAXimum.....	89
FETCh:SUMMary:GIMBalance:MINimum.....	89
FETCh:SUMMary:GIMBalance[:AVERage].....	89
FETCh:SUMMary:IQOFset:MAXimum.....	90
FETCh:SUMMary:IQOFset:MINimum.....	90
FETCh:SUMMary:IQOFset[:AVERage].....	90
FETCh:SUMMary:POWer:MAXimum.....	90
FETCh:SUMMary:POWer:MINimum.....	90
FETCh:SUMMary:POWer[:AVERage].....	90
FETCh:SUMMary:QUADerror:MAXimum.....	90
FETCh:SUMMary:QUADerror:MINimum.....	90
FETCh:SUMMary:QUADerror[:AVERage].....	90
FETCh:SUMMary:SERRor:MAXimum.....	91
FETCh:SUMMary:SERRor:MINimum.....	91
FETCh:SUMMary:SERRor[:AVERage].....	91
FETCh:SUMMary:TFRame.....	91

---

#### FETCh:CYCPrefix?

This command queries the cyclic prefix type that has been detected.

##### Return values:

<PrefixType> The command returns -1 if no valid result has been detected yet.

##### **NORM**

Normal cyclic prefix length detected

##### **EXT**

Extended cyclic prefix length detected

##### Example:

FETC:CYCP?

Returns the current cyclic prefix length type.

##### Usage:

Query only

---

#### FETCh:PLCI:CIDGroup?

This command queries the cell identity group that has been detected.

##### Return values:

<CidGroup> The command returns -1 if no valid result has been detected yet.

Range: 0 to 167

##### Example:

FETC:PLCI:CIDG?

Returns the current cell identity group.

##### Usage:

Query only

---

**FETCh:PLCI:PLID?**

This command queries the cell identity that has been detected.

**Return values:**

<CellIdentity>            The command returns -1 if no valid result has been detected yet.  
Range:            0 to 2

**Example:**

FETC:PLCI:PLID?  
Returns the current cell identity.

**Usage:**

Query only

---

**FETCh:SUMMARY:CRESt[:AVERAge]?**

This command queries the average crest factor as shown in the result summary.

**Return values:**

<CrestFactor>            <numeric value>  
Crest Factor in dB.

**Example:**

FETC:SUMM:CRESt?  
Returns the current crest factor in dB.

**Usage:**

Query only

---

**FETCh:SUMMARY:EVM:PCHannel:MAXimum?  
FETCh:SUMMARY:EVM:PCHannel:MINimum?  
FETCh:SUMMARY:EVM:PCHannel[:AVERAge]?**

This command queries the EVM of all physical channel resource elements.

**Return values:**

<EVM>                    <numeric value>  
Minimum, maximum or average EVM, depending on the last command syntax element.  
The unit is % or dB, depending on your selection.

**Example:**

FETC:SUMM:EVM:PCH:MAX?  
Returns the maximum value.  
FETC:SUMM:EVM:PCH:MIN?  
Returns the minimum value.  
FETC:SUMM:EVM:PCH?  
Returns the mean value.

**Usage:**

Query only

---

**FETCh:SUMMARY:EVM:PSIGNAL:MAXimum?  
FETCh:SUMMARY:EVM:PSIGNAL:MINimum?  
FETCh:SUMMARY:EVM:PSIGNAL[:AVERAge]?**

This command queries the EVM of all physical signal resource elements.

**Return values:****<EVM>** <numeric value>

Minimum, maximum or average EVM, depending on the last command syntax element.

The unit is % or dB, depending on your selection.

**Example:**

```
FETC : SUMM : EVM : PSIG : MAX ?
```

Returns the maximum value.

```
FETC : SUMM : EVM : PSIG : MIN ?
```

Returns the minimum value.

```
FETC : SUMM : EVM : PSIG ?
```

Returns the mean value.

**Usage:**

Query only

**FETCh:SUMMary:EVM[:ALL]:MAXimum?****FETCh:SUMMary:EVM[:ALL]:MINimum?****FETCh:SUMMary:EVM[:ALL][:AVERage]?**

This command queries the EVM of all resource elements.

**Return values:****<EVM>** <numeric value>

Minimum, maximum or average EVM, depending on the last command syntax element.

The unit is % or dB, depending on your selection.

**Example:**

```
FETC : SUMM : EVM : MAX ?
```

Returns the maximum value.

```
FETC : SUMM : EVM : MIN ?
```

Returns the minimum value.

```
FETC : SUMM : EVM ?
```

Returns the mean value.

**Usage:**

Query only

**FETCh:SUMMary:EVM:USQP[:AVERage]?**

This query returns the EVM for all QPSK-modulated resource elements of the PUSCH.

**Return values:****<EVM>** <numeric value>

EVM in % or dB, depending on the unit you have set.

**Example:**

```
FETC : SUMM : EVM : USQP ?
```

Queries the PUSCH QPSK EVM.

**Usage:**

Query only



**FETCh:SUMMary:EVM:USSF[:AVERAge]?**

This query returns the the EVM for all 64QAM-modulated resource elements of the PUSCH.

**Return values:**

<EVM>                    <numeric value>  
EVM in % or dB, depending on the unit you have set.

**Example:**

FETC : SUMM : EVM : USSF ?  
Queries the PUSCH 64QAM EVM.

**Usage:**

Query only

**FETCh:SUMMary:EVM:USST[:AVERAge]?**

This query returns the the EVM for all 16QAM-modulated resource elements of the PUSCH.

**Return values:**

<EVM>                    EVM in % or dB, depending on the unit you have set.

**Example:**

FETC : SUMM : EVM : USST ?  
Queries the PUSCH 16QAM EVM.

**Usage:**

Query only

**FETCh:SUMMary:FERRor:MAXimum?****FETCh:SUMMary:FERRor:MINimum?****FETCh:SUMMary:FERRor[:AVERAge]?**

This command queries the frequency error.

**Return values:**

<FreqError>            <numeric value>  
Minimum, maximum or average frequency error, depending on the last command syntax element.  
Default unit: Hz

**Example:**

FETC : SUMM : FERR ?  
Returns the average frequency error in Hz.

**Usage:**

Query only

**FETCh:SUMMary:GIMBalance:MAXimum?****FETCh:SUMMary:GIMBalance:MINimum?****FETCh:SUMMary:GIMBalance[:AVERAge]?**

This command queries the I/Q gain imbalance.

**Return values:**

<GainImbalance> <numeric value>  
Minimum, maximum or average I/Q imbalance, depending on the last command syntax element.

Default unit: dB

**Example:**

FETC:SUMM:GIMB?

Returns the current gain imbalance in dB.

**Usage:**

Query only

**FETCh:SUMMary:IQOffset:MAXimum?****FETCh:SUMMary:IQOffset:MINimum?****FETCh:SUMMary:IQOffset[:AVERage]?**

This command queries the I/Q offset.

**Return values:**

<IQOffset> <numeric value>

Minimum, maximum or average I/Q offset, depending on the last command syntax element.

Default unit: dB

**Example:**

FETC:SUMM:IQOF?

Returns the current IQ-offset in dB

**Usage:**

Query only

**FETCh:SUMMary:POWER:MAXimum?****FETCh:SUMMary:POWER:MINimum?****FETCh:SUMMary:POWER[:AVERage]?**

This command queries the total power.

**Return values:**

<Power> <numeric value>

Minimum, maximum or average power, depending on the last command syntax element.

Default unit: dBm

**Example:**

FETC:SUMM:POW?

Returns the total power in dBm

**Usage:**

Query only

**FETCh:SUMMary:QUADerror:MAXimum?****FETCh:SUMMary:QUADerror:MINimum?****FETCh:SUMMary:QUADerror[:AVERage]?**

This command queries the quadrature error.

**Return values:****<QuadError>** <numeric value>

Minimum, maximum or average quadrature error, depending on the last command syntax element.

Default unit: deg

**Example:**

FETC:SUMM:QUAD?

Returns the current mean quadrature error in degrees.

**Usage:**

Query only

**FETCh:SUMMary:SERRor:MAXimum?****FETCh:SUMMary:SERRor:MINimum?****FETCh:SUMMary:SERRor[:AVERage]?**

This command queries the sampling error.

**Return values:****<SamplingError>** <numeric value>

Minimum, maximum or average sampling error, depending on the last command syntax element.

Default unit: ppm

**Example:**

FETC:SUMM:SERR?

Returns the current mean sampling error in ppm.

**Usage:**

Query only

**FETCh:SUMMary:TFRame?**

This command queries the trigger to frame result for downlink signals and the trigger to subframe result for uplink signals.

**Return values:****<TrigToFrame>** <numeric value>

Default unit: s

**Example:**

FETC:SUMM:TFR?

Returns the trigger to frame value.

**Usage:**

Query only

## 11.6 FORMat Subsystem

[FORMat\[:DATA\]](#).....91**FORMat[:DATA] [<Format>]**

Specifies the data format for the data transmission between the LTE measurement application and the remote client. Supported formats are ASCII or REAL32.

**Parameters:**

<Format>            ASCII | REAL  
 \*RST:            ASCII

**Return values:**

<BitLen>

**Example:**

FORM REAL  
 The software will send binary data in Real32 data format.

## 11.7 INITiate Subsystem

INITiate[:IMMEDIATE].....	92
INITiate:CONTinuous.....	92
INITiate:REFresh.....	93

---

### INITiate[:IMMEDIATE]

This command initiates a new measurement sequence.

With a frame count > 0, this means a restart of the corresponding number of measurements.

In single sweep mode, you can synchronize to the end of the measurement with \*OPC. In continuous sweep mode, synchronization to the end of the sweep is not possible.

**Example:**

INIT  
 Initiates a new measurement.

**Usage:**

Event

---

### INITiate:CONTinuous <State>

This command controls the sweep mode.

**Parameters:**

<State>            ON | OFF  
**ON**  
 Continuous sweep  
**OFF**  
 Single sweep  
 \*RST:            OFF

**Example:**

INIT:CONT OFF  
 Switches the sequence to single sweep.  
 INIT:CONT ON  
 Switches the sequence to continuous sweep.

**INITiate:REFResh**

This command updates the current I/Q measurement results to reflect the current measurement settings.

No new I/Q data is captured. Thus, measurement settings apply to the I/Q data currently in the capture buffer.

The command applies exclusively to I/Q measurements. It requires I/Q data.

**Example:**                   INIT:REFR  
The application updates the IQ results

**Usage:**                    Event

## 11.8 INPut Subsystem

INPut<n>:ATTenuation<analyzer>.....	93
INPut<n>:DIQ:RANGe[:UPPer].....	93
INPut<n>:DIQ:SRATe.....	93
INPut:EATT:AUTO.....	94
INPut:SELEct.....	94

**INPut<n>:ATTenuation<analyzer> <Attenuation>**

This command sets the RF attenuation for an analyzer in the test setup.

**Parameters:**  
<Attenuation>            <numeric value>  
                          \*RST:       5 dB  
                          Default unit: dB

**Example:**               INP:ATT 10  
Defines an RF attenuation of 10 dB.

**INPut<n>:DIQ:RANGe[:UPPer] <ScaleLevel>**

This command defines the full scale level for a digital I/Q signal source.

**Parameters:**  
<ScaleLevel>            Numeric value  
                          \*RST:       1 V  
                          Default unit: V

**Example:**               INP:DIQ:RANG 0.7  
Sets the full scale level to 0.7 V.

**INPut<n>:DIQ:SRATe <SampleRate>**

This command defines the sampling rate for a digital I/Q signal source.

**Parameters:**

<SampleRate> \*RST: 10 MHz  
Default unit: Hz

**Example:**

INP:DIQ:SRAT 10MHZ  
Defines a sampling rate of 10 MHz.

**INPut:EATT:AUTO <State>**

Switches the automatic behaviour of the electronic attenuator on or off. If activated, electronic attenuation is used to reduce the operation of the mechanical attenuation whenever possible.

This command is only available with option R&S FSV-B25, but not if R&S FSV-B17 is active.

**Parameters:**

<State> ON | OFF  
\*RST: ON

**Example:**

INP1:EATT:AUTO OFF

**Mode:**

all

**INPut:SElect <Source>**

This command selects the data source.

**Parameters:**

<Source> **RF**  
Selects the RF input as the data source.

**AIQ**

Selects the analog baseband input as the data source. This source is available only with option R&S FSVR-B71.

**DIQ**

Selects the digital baseband input as the data source. This source is available only with option R&S FSVR-B17.

## 11.9 INSTrument Subsystem

**INSTrument[:SElect] <Mode> | <ChannelName>**

This command selects the measurement mode by means of text parameters.

**Parameters:**

&lt;Mode&gt;

**SANalyzer**

Spectrum mode

**ADEMod**

Analog demodulation mode

(Analog Demodulation option, R&amp;S FSV-K7)

**SFM**

FM Stereo (R&amp;S FSV-K7S option)

**BTOoth**

Bluetooth mode (R&amp;S FSV-K8 option)

**GSM | MGSM**

GSM mode (R&amp;S FSV-K10 option)

Query returns MGSM.

**NOISe**

Noise Figure Measurements option, R&amp;S FSV-K30

**PNOise**

Phase Noise mode (R&amp;S FSV-K40 option)

**DDEM**

VSA mode (R&amp;S FSV-K70 option)

**BWCD**

3G FDD BTS Mode (R&amp;S FSV-K72 option)

**MWCD**

3G FDD UE Mode (R&amp;S FSV-K73 option)

**BTDS**

TD-SCDMA BTS mode (R&amp;S FSV-K76 option)

**MTDS**

TD-SCDMA UE mode (R&amp;S FSV-K77 option)

**BC2K**

CDMA2000 BS Analysis mode (R&amp;S FSV-K82 option)

**BDO**

1xEV-DO BS Analysis option, R&amp;S FSV-K84

**WLAN**

WLAN TX mode (R&amp;S FSV-K91/91n option)

**WiMAX**

WiMax mode (WiMAX 802.16 OFDM Measurements option and WiMAX IEEE 802.16 OFDM, OFDMA Measurements option, R&amp;S FSV-K93)

**LTE**

LTE measurement application (uplink and downlink)

\*RST: SANalyzer

**Example:**

INST SAN

Switches the instrument to "Spectrum" mode.

**Usage:**

SCPI confirmed

**Mode:**                   all

---

**INSTrument:NSElect** <Mode>

This command selects the operating mode by means of numbers.



**Parameters:**

<Mode>	Selects the operating with numbers.
<b>1</b>	Spectrum mode
<b>2</b>	VSA mode (R&S FSV-K70 option)
<b>3</b>	Analog demodulation mode
<b>5</b>	GSM mode (R&S FSV-K10 option)
<b>6</b>	Selects WiMax mode (WiMAX IEEE 802.16 OFDM, OFDMA Measurements option, R&S FSV-K93)
<b>7</b>	FM Stereo (R&S FSV-K7S option)
<b>8</b>	3G FDD BTS Mode (R&S FSV-K72 option)
<b>9</b>	3G FDD UE Mode (R&S FSV-K73 option)
<b>10</b>	CDMA2000 BS Analysis mode (R&S FSV-K82 option)
<b>12</b>	Bluetooth mode (R&S FSV-K8 option)
<b>14</b>	1xEV-DO BS Analysis mode (R&S FSV-K84 option)
<b>16</b>	Selects WLAN TX mode (R&S FSV-K91/91n option)
<b>17</b>	TD-SCDMA BTS mode (R&S FSV-K76 option)
<b>18</b>	TD-SCDMA UE mode (R&S FSV-K77 option)
<b>19</b>	Noise Figure mode (R&S FSV-K30 option)
<b>20</b>	Phase Noise mode ((R&S FSV-K40 option)
<b>23</b>	Selects WiMax mode (WiMAX 802.16 OFDM Measurements option, R&S FSV-K93)
<b>100</b>	LTE measurement application (uplink and downlink)
*RST:	1

**Example:**

```
INST:NSEL 1
```

Switches the instrument to "Spectrum" mode.

**Usage:**

SCPI confirmed

**Mode:** all

## 11.10 MMEMory Subsystem

[MMEMory:LOAD:DEModsettings](#).....98

---

### **MMEMory:LOAD:DEModsettings** <Path>

This command restores previously saved demodulation settings.

The file must be of type "\*.allocation" and depends on the link direction that was currently selected when the file was saved. You can load only files with correct link directions.

#### **Setting parameters:**

<Path> String containing the path and name of the file.

**Example:** MMEM:LOAD:DEM 'D:\USER\Settingsfile.allocation'

**Usage:** Setting only

## 11.11 SENSE Subsystem

<a href="#">[SENSe][:LTE]:FRAMe:COUNT</a> .....	98
<a href="#">[SENSe][:LTE]:FRAMe:COUNT:AUTO</a> .....	99
<a href="#">[SENSe][:LTE]:FRAMe:COUNT:STATe</a> .....	99
<a href="#">[SENSe][:LTE]:SLOT:SElect</a> .....	99
<a href="#">[SENSe][:LTE]:SUBFrame:SElect</a> .....	100
<a href="#">[SENSe][:LTE]:UL:DEMod:AUTO</a> .....	100
<a href="#">[SENSe][:LTE]:UL:DEMod:CBSCrambling</a> .....	100
<a href="#">[SENSe][:LTE]:UL:DEMod:CDOffset</a> .....	100
<a href="#">[SENSe][:LTE]:UL:DEMod:CESTimation</a> .....	101
<a href="#">[SENSe][:LTE]:UL:DEMod:SISync</a> .....	101
<a href="#">[SENSe][:LTE]:UL:TRACking:PHASe</a> .....	101
<a href="#">[SENSe][:LTE]:UL:TRACking:TIME</a> .....	101
<a href="#">[SENSe]:FREQuency:CENTer</a> .....	102
<a href="#">[SENSe]:POWEr:ACHannel:AACHannel</a> .....	102
<a href="#">[SENSe]:POWEr:AUTO&lt;analyzer&gt;[:STATe]</a> .....	102
<a href="#">[SENSe]:POWEr:AUTO&lt;analyzer&gt;:TIME</a> .....	103
<a href="#">[SENSe]:POWEr:NCORrection</a> .....	103
<a href="#">[SENSe]:POWEr:SEM:CATegory</a> .....	103
<a href="#">[SENSe]:SWAPiq</a> .....	103
<a href="#">[SENSe]:SWEp:TIME</a> .....	104

---

### **[SENSe][:LTE]:FRAMe:COUNT** <Subframes>

This command sets the number of frames you want to analyze.

**Parameters:**

<Subframes> <numeric value>  
 \*RST: 1

**Example:**

FRAM:COUN:STAT ON  
 Activates manual input of frames to be analyzed.  
 FRAM:COUN 20  
 Analyzes 20 frames.

**[SENSe][:LTE]:FRAMe:COUNT:AUTO <State>**

This command turns automatic selection of the number of frames to analyze on and off.

**Parameters:**

<State> **ON**  
 Selects the number of frames to analyze according to the LTE standard.

**OFF**  
 Turns manual selection of the frame number on.

**Example:**

FRAM:COUN:AUTO ON  
 Turns automatic selection of the analyzed frames on.

**[SENSe][:LTE]:FRAMe:COUNT:STATe <State>**

This command turns manual selection of the number of frames you want to analyze on and off.

**Parameters:**

<State> **ON**  
 You can set the number of frames to analyze.

**OFF**  
 The R&S FSVR analyzes a single sweep.

\*RST: ON

**Example:**

FRAM:COUN:STAT ON  
 Turns manual setting of number of frames to analyze on.

**[SENSe][:LTE]:SLOT:SElect <Slot>**

This command selects the slot to analyze.

**Parameters:**

<Slot> **S0**  
 Slot 0

**S1**  
 Slot 1

**ALL**  
 Both slots

\*RST: ALL

**Example:**           SLOT:SEL S1  
                          Selects slot 1 for analysis.

---

**[SENSe][:LTE]:SUBFrame:SElect <Subframe>**

This command selects the subframe to be analyzed.

**Parameters:**

<Subframe>           ALL | <numeric value>  
                          **ALL**  
                          Select all subframes  
                          **0...39**  
                          Select a single subframe  
                          \*RST:        ALL

**Example:**           SUBF:SEL ALL  
                          Select all subframes for analysis.

---

**[SENSe][:LTE]:UL:DEMod:AUTO <State>**

This command turns automatic demodulation for uplink signals on and off.

**Parameters:**

<State>               ON | OFF  
                          \*RST:        ON

**Example:**           UL:DEM:AUTO OFF  
                          Deactivates automatic demodulation.

---

**[SENSe][:LTE]:UL:DEMod:CBSCrambling <State>**

This command turns scrambling of coded bits for uplink signals on and off.

**Parameters:**

<State>               ON | OFF  
                          \*RST:        ON

**Example:**           UL:DEM:CBSC OFF  
                          Deactivates the scrambling.

---

**[SENSe][:LTE]:UL:DEMod:CDOffset <State>**

This command turns DC offset compensation for uplink signals on and off.

**Parameters:**

<State>               ON | OFF  
                          \*RST:        ON

**Example:**           UL:DEM:CD OFF  
                          Deactivates DC offset compensation.

---

**[SENSe][:LTE]:UL:DEMod:CESTimation <Type>**

This command selects the channel estimation type for uplink signals.

**Parameters:**

<Type>                   PIL | PILPAY  
**PIL**  
Pilot only  
**PILP**  
Pilot and payload  
\*RST:            PILP

**Example:**

UL:DEMod:CEST PIL  
Uses only the pilot signal for channel estimation.

---

**[SENSe][:LTE]:UL:DEMod:SISync <State>**

This command turns suppressed interference synchronization on and off.

**Parameters:**

<State>                   ON | OFF  
\*RST:            OFF

**Example:**

UL:DEMod:SISY ON  
Turns suppressed interference synchronization on.

---

**[SENSe][:LTE]:UL:TRACking:PHASe <Type>**

This command selects the phase tracking type for uplink signals.

**Parameters:**

<Type>                   **OFF**  
Deactivate phase tracking  
**PIL**  
Pilot only  
**PILP**  
Pilot and payload  
\*RST:            OFF

**Example:**

SENS:UL:TRAC:PHAS PILP  
Use pilots and payload for channel estimation.

---

**[SENSe][:LTE]:UL:TRACking:TIME <State>**

This command turns timing tracking for uplink signals on and off.

**Parameters:**

<State>                   ON | OFF  
\*RST:            OFF

**Example:** `UL:TRAC:TIME ON`  
Activates timing tracking.

---

**[SENSe]:FREQuency:CENTer** <Frequency>

This command sets the center frequency for RF measurements.

**Parameters:**

<Frequency>            <numeric value>  
Range:            fmin to fmax  
\*RST:            1 GHz  
Default unit: Hz

**Example:** `FREQ:CENT 2GHZ`  
Set the center frequency to 2 GHz.

---

**[SENSe]:POWer:ACHannel:AACHannel** <Channel>

This command selects the assumed adjacent channel carrier for ACLR measurements.

**Parameters:**

<Channel>            **EUTRA**  
Selects an EUTRA signal of the same bandwidth like the TX channel as assumed adjacent channel carrier.

**UTRA128**  
Selects an UTRA signal with a bandwidth of 1.28MHz as assumed adjacent channel carrier.

**UTRA384**  
Selects an UTRA signal with a bandwidth of 3.84MHz as assumed adjacent channel carrier.

**UTRA768**  
Selects an UTRA signal with a bandwidth of 7.68MHz as assumed adjacent channel carrier.

\*RST:            EUTRA

**Example:** `POW:ACH:AACH UTRA384`  
Selects an UTRA signal with a bandwidth of 3.84MHz as assumed adjacent channel carrier.

---

**[SENSe]:POWer:AUTO<analyzer>[:STATe]** <State>

This command initiates a measurement that determines the ideal reference level.

**Parameters:**

&lt;State&gt;

**OFF**

Performs no automatic reference level detection.

**ON**

Performs an automatic reference level detection before each measurement.

**ONCE**

Performs an automatic reference level once.

**\*RST:** ON**Example:**

POW:AUTO2 ON

Activate auto level for analyzer number 2.

**[SENSe]:POWer:AUTO<analyzer>:TIME <Time>**

This command defines the track time for the auto level process.

**Parameters:**

&lt;Time&gt;

&lt;numeric value&gt;

**\*RST:** 100 ms

Default unit: s

**Example:**

POW:AUTO:TIME 200ms

An auto level track time of 200 ms gets set.

**[SENSe]:POWer:NCORrection <State>**

This command turns noise correction for ACLR measurements on and off.

**Parameters:**

&lt;State&gt;

ON | OFF

**\*RST:** OFF**Example:**

POW:NCOR ON

Activates noise correction.

**[SENSe]:POWer:SEM:CATegory <Category>**

This command selects the SEM limit category as defined in 3GPP TS 36.101.

**Parameters:**

&lt;Category&gt;

A | B

**\*RST:** A**Example:**

POW:SEM:CAT B

Selects SEM category B.

**[SENSe]:SWAPiq <State>**

This command turns a swap of the I and Q branches on and off.

**Parameters:**

<State> ON | OFF  
 \*RST: OFF

**Example:**

SWAP ON  
 Turns a swap of the I and Q branches on.

**[SENSe]:SWEep:TIME <CaptLength>**

This command sets the capture time.

**Parameters:**

<CaptLength> Numeric value in seconds.  
 Default unit: s

**Example:**

SWE:TIME 40  
 Defines a capture time of 40 seconds.

## 11.12 TRACe Subsystem

### Example for querying the results of the allocation summary result display

This section shows an example of what the R&S FSVR will return when the Allocation Summary result display is queried with the TRACe[:DATA] command.

B Allocation Summary							
Sub-frame	Allocation ID	Number of RB	Offset RB	Modulation	Power [dBm]	EVM [%]	
0	PUSCH	46	2	QPSK	-30.871	0.311	▲
	DMRS PUSCH			PSK	-30.871	0.281	
1	PUSCH	46	2	QPSK	-30.871	0.291	▲
	DMRS PUSCH			PSK	-30.871	0.287	
2	PUSCH	46	2	QPSK	-30.870	0.298	▲
	DMRS PUSCH			PSK	-30.871	0.259	
3	PUSCH	46	2	QPSK	-30.870	0.302	▼
	DMRS PUSCH			PSK	-30.871	0.303	

Fig. 11-1: Display of the allocation summary

The TRACe[:DATA] command would return this:

```
<subframe>, <allocation ID>, <number of RB>, <offset RB>,
<modulation>, <power in dBm>, <EVM in dB or %>, ...
```

Each line in this example corresponds to one set of values.

```
0,-5,24,2,0,-17.8716996097583,8.44728660354122E-06,
0,-3,24,2,0,-17.742108013101,8.49192574037261E-06,
0,-4,24,2,0,-17.7421077124897,8.50963104426228E-06,
0,-12,24,,2,-17.092699868618,7.81896929424875E-06,
```



```
0,0,3,0,4,-17.1774446884892,8.54281765327869E-06,
0,1,1,3,3,-17.1688944558343,9.53971195372105E-06,...
<continues like this until the end of data is reached>
```

**Example for querying the results of the bitstream result display**

This section shows an example of what the R&S FSVR will return when the Bitstream result display is queried with the TRACe[:DATA] command.

Sub-frame	Modulation	Symbol Index	Bit Stream
0	QPSK	0	00 02 03 00 03 03 00 01 03 03 01 03 01 00 00 01
0	QPSK	16	02 02 03 01 02 03 02 03 00 00 01 01 02 02 03 03
0	QPSK	32	02 02 02 02 02 00 00 01 01 00 02 02 03 03 00 02
0	QPSK	48	03 02 03 02 00 00 01 03 00 03 02 02 01 00 03 03
0	QPSK	64	01 01 03 01 01 00 01 00 02 00 01 02 01 03 00 00
0	QPSK	80	02 03 03 01 02 03 00 03 01 00 00 03 02 03 03 00
0	QPSK	96	00 03 03 03 03 02 00 00 03 03 01 03 03 00 01 01
0	QPSK	112	03 00 03 00 02 00 00 02 01 01 00 03 02 03 01 00
0	QPSK	128	01 03 02 01 03 03 00 03 01 02 00 02 02 02 01 00
0	QPSK	144	01 03 00 01 02 03 01 01 01 03 00 01 00 03 00 01
0	QPSK	160	00 01 00 00 00 00 02 00 01 00 01 02 00 01 00 03

Fig. 11-2: Display of the bitstream

The TRACe[:DATA] command would return this:

```
<subframe>, <modulation>, <number of symbols or bits>,
<hexadecimal or binary numbers>, ...
```

Each line in this example corresponds to one set of values.

```
0,2,1440,02,00,00,02,01,01,02,00,00,02,00,02,03,02,01,02,02,
00,03,02,02,01,02,00,03,02,02,02,03,02,03,03,00,00,01,02,...
<continues like this until the next data block starts or the end of data is reached>

...,1,2,1440,03,00,02,00,02,01,01,01,01,03,00,00,03,03,03,02,
03,02,03,02,00,03,03,03,01,01,00,03,00,02,03,03,02,00,01,...
<continues like this till next datablock starts or end of data reached>
```

TRACe[:DATA].....105

**TRACe[:DATA]? <TraceNumber> | LIST**

This command returns the trace data for the current measurement or result display. You can change the format of the returned data with the FORMat[:DATA] command.

**ASCII format (FORMat ASCII):** In ASCII format, a list of values separated by commas is returned (Comma Separated Values = CSV). Empty fields will return NAN.

**Binary format (FORMat REAL,32):** If the transmission takes place using the binary format (REAL,32), the data are transferred in block format (Definite Length Block Data according to IEEE 488.2). They are arranged in succeeding lists of I and Q data of 32 Bit IEEE 754 floating point numbers.

The returned values are scaled in the current measurement unit. For some measurements the unit may change depending on the unit set with UNIT:EVM.

The format of the data that is returned is specific to each result display and is specified below.

- **Capture Buffer**  
 For the Capture Buffer result display, the command returns one value for each I/Q sample in the capture buffer. The unit is dBm.
- **EVM vs Carrier**  
 For the EVM vs Carrier result display, the command returns one value for each sub-carrier. The unit is either dB or %, depending on the unit you have set.  
 <EVM in dB | EVM in %>, ...  
 The command returns the following for parameter TRACE1 to TRACE3, depending on the Subframe Configuration  
 TRACE1: Mean EVM (averaged over all subframes)  
 TRACE2: Minimum EVM or nothing if a single subframe is selected  
 TRACE3: Maximum EVM or nothing if a single subframe is selected
- **EVM vs Symbol**  
 For the EVM vs Symbol result display, the command returns a value for each OFDM symbol. If you select a single subframe ([SENSe] [:LTE] :SUBFrame:SElect), the command returns only the symbols of that subframe. The unit is either dB or %, depending on the unit you have set.  
 <EVM in dB | EVM in %>, ...  
 The command returns data only for parameter TRACE1.
- **EVM vs Subframe**  
 For the EVM vs Subframe result display, the command returns a value for each sub-frame. The unit is either dB or %, depending on the unit you have set.  
 <EVM in dB | EVM in %>, ...  
 The command returns data only for parameter TRACE1.
- **Spectrum Emission Mask**  
 For the Spectrum Emission Mask result display, the command returns one value for each trace point for parameter TRACE1.  
 <power in dBm>  
 For parameter LIST, it returns the contents of the SEM table.  
 <index in result table>, <start frequency band in Hz>, <stop frequency band in Hz>, <RBW in Hz>, <limit fail frequency in Hz>, <absolute power in dBm>, <relative power in dBc>, <limit distance in dB>, <failure flag>, ...  
 The <failure flag> element returns 1 for FAIL and 0 for PASS.
- **Adjacent Channel Leakage Ratio**  
 For the ACLR result display, the command returns one value for each trace point for parameter TRACE1.  
 <power in dBm>, ...  
 For parameter LIST, it returns the contents of the ACLR table.
- **Inband Emission**  
 For the Inband Emission result display, the command returns the relative inband emission of the current slot.  
 <power in dB>, ...

The command returns the following for parameter TRACE1 to TRACE3, depending on the Subframe Configuration.

TRACE1: relative resource block indexes (x-axis of the plot)

TRACE2: relative inband emission values (dB)

TRACE3: upper limit line values (dB)

If all subframes are selected, the command returns nothing.

- **Power Spectrum**

For the Power Spectrum result display, the command returns the signal power in dBm/Hz as list over the considered frequency span for parameter TRACE1

<power in dB>

- **Channel Flatness**

For the Channel Flatness result display, the command returns one value for each trace point.

<spectrum flatness in dB>, ...

The number of trace points depends on the LTE bandwidth.

The command returns the following for parameter TRACE1 to TRACE3, depending on the Subframe Configuration

TRACE1: mean power of the channel flatness (averaged over all subframes)

TRACE2: minimum power of the channel flatness or nothing if a single subframe is selected

TRACE3: maximum power of the channel flatness or nothing if a single subframe is selected

- **Channel Group Delay**

For the Channel Group Delay result display, the command returns one value for each trace point.

<channel group delay in ns>

The number of trace points depends on the LTE bandwidth.

The command returns the following for parameter TRACE1 to TRACE3, depending on the Subframe Configuration

TRACE1: Mean time of the channel group delay (averaged over all subframes)

TRACE2: Minimum time of the channel group delay or nothing if a single subframe is selected

TRACE3: Maximum time of the channel group delay or nothing if a single subframe is selected

- **Channel Flatness Difference**

For the Channel Flatness Difference result display, the command returns one value for each trace point.

<channel flatness difference in dB>, ...

The number of trace points depends on the LTE bandwidth.

The command returns the following for parameter TRACE1 to TRACE3, depending on the Subframe Configuration

TRACE1: Mean power of the channel flatness difference (averaged over all subframes)

TRACE2: Minimum power of the channel flatness difference or nothing if a single subframe is selected

TRACE3: Maximum power of the channel flatness difference or nothing if a single subframe is selected

- **Constellation Diagram**

For the Constellation Diagram result display, the command returns an array of interleaved I and Q data until all data is exhausted.

By default, the command returns all measured data points. You can reduce the amount of data by filtering the results via "[Constellation Selection](#)" on page 54.

Constellation data is returned in the following order.

- Subframe 0, Symbol 0: first to last carrier of symbol 0
- Subframe 0, Symbol 1: first to last carrier of symbol 1
- Subframe 0, (...) to last symbol of subframe 0
- Subframe 1, Symbol 0: first to last carrier of symbol 0
- Subframe 1, Symbol 1: first to last carrier of symbol 1
- Subframe 1, (...) to last symbol of subframe 1
- (...) to last subframe

TRACE1: all constellation data covered by the selection

TRACE2: reference symbols covered by the selection

TRACE3: sounding reference signal covered by the selection

- **DFT Precoded Constellation**

For the DFT Precoded Constellation result display, the command returns an array of interleaved I and Q data until all data is exhausted.

- **CCDF**

For the Complementary Cumulative Distribution Function result display, the command returns the probability over the power level.

The first value returned represents the number of following values.

The command returns the following for parameter TRACE1 to TRACE2

TRACE1: returns the values of the y-axis: <probability value in %>

TRACE2: returns the corresponding values of the x-axis: <power steps in dB>

- **Allocation Summary**

For the Allocation Summary result display, the command returns seven values for each line of the allocation summary table.

<subframe>, <allocation ID>, <number of RB>, <offset RB>, <modulation>, <power in dBm>, <EVM in dB or %>, ...

This command is not available for Real32 data format and will therefore always return ASCII formatted data.

- **Bitstream**

For the BitStream result display, the command returns returns six values for each line in the bitstream table.

<subframe>, <modulation>, <number of symbols or bits>, <hexadecimal or binary numbers>, ...

This command is not available for Real32 data format and will therefore always return ASCII formatted data.

**Parameters:**

<hexadecimal or binary numbers> In Hexmode, a comma-separated stream of two-digit hexadecimal numbers and in binary mode a comma-separated stream of binary numbers.

<number of symbols or bits> In Hexmode, the number of symbols to be transmitted and in binary mode the number of bits to be transmitted.

**Parameters for setting and query:**

<TraceNumber> **TRACE1 | TRACE2 | TRACE3**  
 If you have more than one trace in the result display, this parameter selects the trace whose data you want.

**Return values:**

<allocation ID> Allocation ID for uplink signals.  
**1**= Reference symbol  
**0**= Data symbol  
**-1**= Not analyzed  
**-40**= PUSCH  
**-41**= DMRS PUSCH  
**-42**= SRS PUSCH  
**-50**= PUCCH  
**-51**= DMRS PUCCH  
**-70**= PRACH

<EVM> EVM is returned either in dB or in %, depending on the unit you have set.

<modulation> Type of modulation. The range is {0...8}.  
**0**= Unrecognized  
**1**= RBPSK (both constellation points are located on the x-axis)  
**2**= QPSK  
**3**= 16QAM  
**4**= 64QAM  
**5**= 8PSK  
**6**= PSK  
**7**= Modulation mixture  
**8**= BPSK

<number of RB> Number of resource blocks.

<offset RB> Offset resource blocks.

<subframe> Number of the subframe.

**Usage:** Query only

## 11.13 TRIGger Subsystem

TRIGger[:SEquence]:HOLDoff<analyzer>.....	109
TRIGger[:SEquence]:LEVel<analyzer>[:EXternal].....	110
TRIGger[:SEquence]:MODE.....	110

---

**TRIGger[:SEquence]:HOLDoff<analyzer> <Offset>**

This command defines the trigger offset.

**Parameters:**

<Offset> <numeric value>  
 \*RST: 0 s  
 Default unit: s

**Example:**

TRIG:HOLD 5MS  
 Sets the trigger offset to 5 ms.

**TRIGger[:SEQuence]:LEVel<analyzer>[:EXTeRnal] <Level>**

This command defines the level for an IF power trigger.

**Parameters:**

<Level> Range: 0.5 V to 3.5 V  
 \*RST: 1.4 V  
 Default unit: V

**Example:**

TRIG:LEV 2V

**TRIGger[:SEQuence]:MODE <Source>**

This command selects the trigger source.

**Parameters:**

<Source> **EXTeRnal**  
 Selects external trigger source.

**IMMeDiate**  
 Selects free run trigger source.

**POWeR**  
 Selects IF power trigger source.

**PSEn**  
 Selects power sensor trigger source.

**RFPOweR**  
 Selects RF power trigger source.

\*RST: IMMeDiate

**Example:**

TRIG:MODE EXT  
 Selects an external trigger source.

## 11.14 UNIT Subsystem

UNIT:BSTR.....	110
UNIT:EVM.....	111

**UNIT:BSTR <Unit>**

This command selects the way the bit stream is displayed.

**Parameters:**

&lt;Unit&gt;

**SYMBOLS**

Displays the bit stream using symbols

**BITS**

Displays the bit stream using bits

\*RST:       SYMBOLS

**Example:**

UNIT:BSTR BIT

Bit stream gets displayed using Bits.

**UNIT:EVM <Unit>**

This command selects the EVM unit.

**Parameters:**

&lt;Unit&gt;

**DB**

EVM results returned in dB

**PCT**

EVM results returned in %

\*RST:       PCT

**Example:**

UNIT:EVM PCT

EVM results to be returned in %.

## 11.15 Status Reporting System (LTE Measurements)

The status reporting system stores information about the current state of the R&S FSVR. This includes, for example, information about errors during operation or information about limit checks. The R&S FSVR stores this information in the status registers and in the error queue. You can query the status register and error queue via IEC bus.

The R&S FSVR structures the information hierarchically, with the Status Byte register (STB) and the Service Request Enable mask register (SRE) being on the highest level. The STB gets its information from the standard Event Status Register (ESR) and the Event Status Enable mask register (ESE). The STB and ESR are both defined by IEEE 488.2. In addition to the ESR, the STB also gets information from the STATus:OPERation and STATus:QUESTionable registers. These are the link to the lower levels of the status register and are defined by SCPI. They contain information about the state of the R&S FSVR.

In addition to the status registers of the base system, the LTE measurement application provides additional or different registers specific to this firmware option. This chapter describes the registers specific to the LTE measurement applications (uplink and downlink). For a description of the other registers see the operating manual of the R&S FSVR.

Overview of the status register

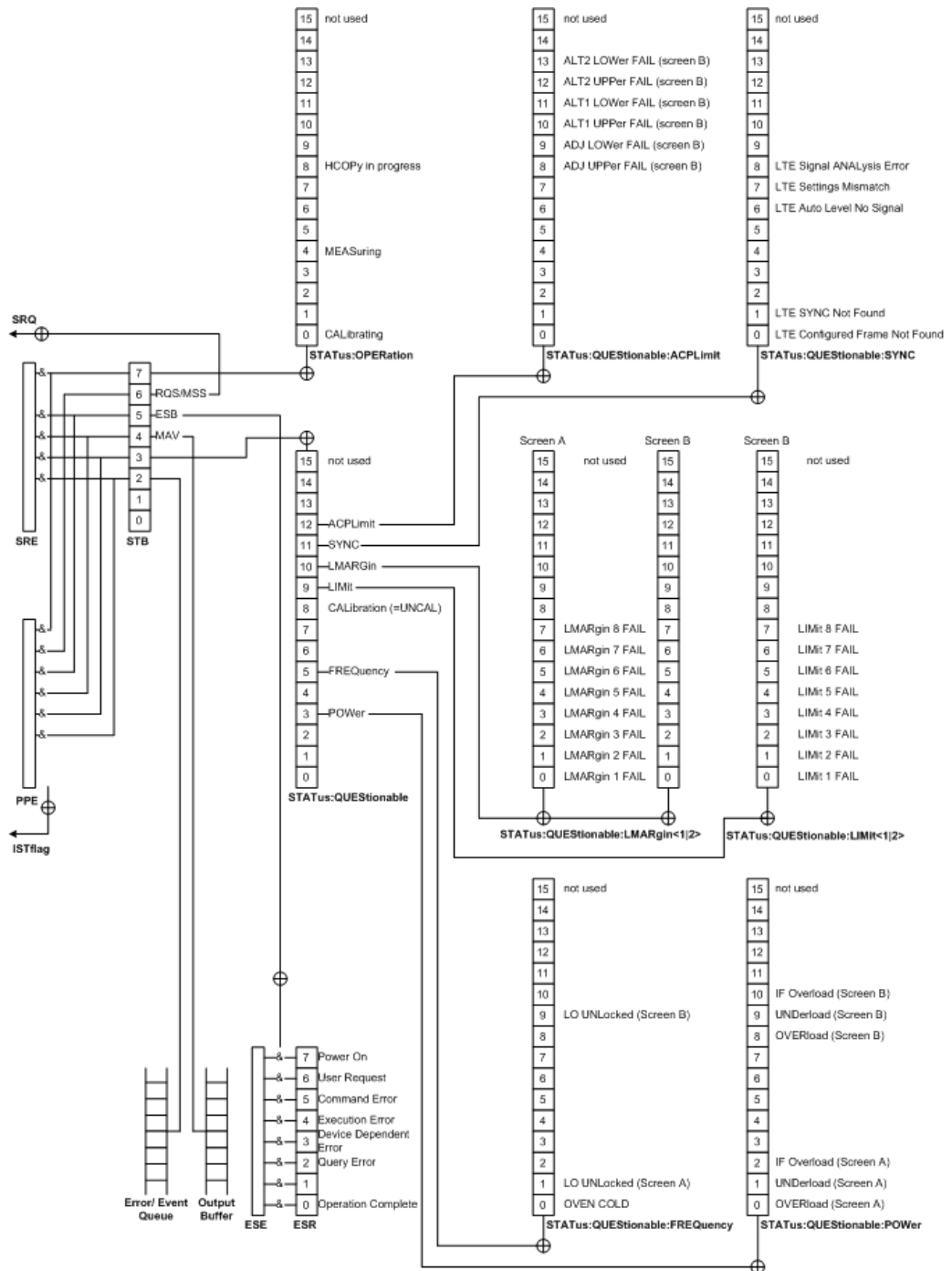

11.15.1 STATus:QUESTIONable:LIMit Register

The STATus:QUESTIONable:LIMit register contains information about the results of a limit check when you are working with limit lines.



The LTE measurement application contains one LIMit register only because limit lines are always displayed in screen B.

The number of LIMit registers depends on the number of measurement windows available in any operating mode.

You can read out the register with `STATus:QUEStionable:LIMit[:EVENT]` or `STATus:QUEStionable:LIMit:CONDition`. For more information see the manual of the base unit.

**Table 11-1: Meaning of the bits used in the `STATus:QUEStionable:LIMit` register**

Bit No.	Meaning
0	LIMit 1 FAIL This bit is set if limit line 1 is violated.
1	LIMit 2 FAIL This bit is set if limit line 2 is violated.
2	LIMit 3 FAIL This bit is set if limit line 3 is violated.
3	LIMit 4 FAIL This bit is set if limit line 4 is violated.
4	LIMit 5 FAIL This bit is set if limit line 5 is violated.
5	LIMit 6 FAIL This bit is set if limit line 6 is violated.
6	LIMit 7 FAIL This bit is set if limit line 7 is violated.
7	LIMit 8 FAIL This bit is set if limit line 8 is violated.
8 to 14	Unused
15	This bit is always 0.

### 11.15.2 `STATus:QUEStionable:SYNC` Register

The `STATus:QUEStionable:SYNC` register contains information about the synchronization of the R&S FSVR to the signal.

You can read out the register with `STATus:QUEStionable:SYNC[:EVENT]` or `STATus:QUEStionable:SYNC:CONDition`. For more information see the manual of the base unit.

**Table 11-2: Meaning of the bits used in the STATus:QUESTIONable:LIMit register**

Bit No.	Meaning
0	LTE Configured Frame Not Found This bit is set if the application could not find the configured frame. Only possible with uplink measurements.
1	SYNC Not Found This bit is set if the application could not synchronize to the signal. Only possible with downlink measurements.
2 to 5	Unused
6	LTE Auto Level No Signal
7	LTE Settings Mismatch This bit is set if the configuration is not the same as the signal.
8	LTE Signal Analysis Error
9 to 14	Unused
15	This bit is always 0.

## List of Commands

CALCulate<n>:FEED.....	70
CALCulate<n>:MARKer<m>:AOFF.....	71
CALCulate<n>:MARKer<m>:FUNctIon:POWer:RESult[:CURRent].....	71
CALCulate<n>:MARKer<m>:TRACe.....	72
CALCulate<n>:MARKer<m>:X.....	72
CALCulate<n>:MARKer<m>:Y.....	72
CALCulate<n>:MARKer<m>[:STATe].....	71
CONFIgure:POWer:EXPEcted:IQ<analyzer>.....	84
CONFIgure:POWer:EXPEcted:RF<analyzer>.....	84
CONFIgure[:LTE]:DL:PLC:CIDGroup.....	74
CONFIgure[:LTE]:DUPLexing.....	74
CONFIgure[:LTE]:LDIRection.....	74
CONFIgure[:LTE]:UL:BW.....	74
CONFIgure[:LTE]:UL:CSUBframes.....	75
CONFIgure[:LTE]:UL:CYCPrefix.....	75
CONFIgure[:LTE]:UL:DRS:DSSHift.....	75
CONFIgure[:LTE]:UL:DRS:ENPR.....	75
CONFIgure[:LTE]:UL:DRS:GRPHopping.....	76
CONFIgure[:LTE]:UL:DRS:PUCCh:POWer.....	76
CONFIgure[:LTE]:UL:DRS:SEQHopping.....	76
CONFIgure[:LTE]:UL:DRS[:PUSCh]:POWer.....	76
CONFIgure[:LTE]:UL:NORB.....	77
CONFIgure[:LTE]:UL:PLC:CIDGroup.....	77
CONFIgure[:LTE]:UL:PLC:PLID.....	77
CONFIgure[:LTE]:UL:PUCCh:DEOfset.....	77
CONFIgure[:LTE]:UL:PUCCh:DESHift.....	78
CONFIgure[:LTE]:UL:PUCCh:FORMat.....	78
CONFIgure[:LTE]:UL:PUCCh:N1CS.....	78
CONFIgure[:LTE]:UL:PUCCh:N2RB.....	78
CONFIgure[:LTE]:UL:PUCCh:NORB.....	79
CONFIgure[:LTE]:UL:PUSCh:FHMode.....	79
CONFIgure[:LTE]:UL:PUSCh:FHOFFset.....	79
CONFIgure[:LTE]:UL:PUSCh:FHOP:IIHB.....	79
CONFIgure[:LTE]:UL:PUSCh:NOSM.....	80
CONFIgure[:LTE]:UL:SFNO.....	80
CONFIgure[:LTE]:UL:SRS:BHOP.....	80
CONFIgure[:LTE]:UL:SRS:BSRS.....	80
CONFIgure[:LTE]:UL:SRS:CSRS.....	81
CONFIgure[:LTE]:UL:SRS:CYCS.....	81
CONFIgure[:LTE]:UL:SRS:ISRS.....	81
CONFIgure[:LTE]:UL:SRS:NRRC.....	81
CONFIgure[:LTE]:UL:SRS:POWer.....	82
CONFIgure[:LTE]:UL:SRS:STAT.....	82
CONFIgure[:LTE]:UL:SRS:SUConfig.....	82
CONFIgure[:LTE]:UL:SRS:TRComb.....	82

CONFigure[:LTE]:UL:SUBFrame<subframe>:ALLoc:CONt.....	82
CONFigure[:LTE]:UL:SUBFrame<subframe>:ALLoc:MODulation.....	83
CONFigure[:LTE]:UL:SUBFrame<subframe>:ALLoc:POWer.....	83
CONFigure[:LTE]:UL:SUBFrame<subframe>:ALLoc:RBCount.....	83
CONFigure[:LTE]:UL:SUBFrame<subframe>:ALLoc:RBOFset.....	84
CONFigure[:LTE]:UL:TDD:UDConf.....	84
CONFigure[:LTE]:UL:UEID.....	84
DISPlay[:WINDow<n>]:SELect.....	85
DISPlay[:WINDow<n>]:TRACe<t>:Y[:SCALE]:RLEVel:OFFSet.....	85
FETCh:CYCPrefix.....	86
FETCh:PLCI:CIDGroup.....	86
FETCh:PLCI:PLID.....	87
FETCh:SUMMary:CRESt[:AVERage].....	87
FETCh:SUMMary:EVM:PCHannel:MAXimum.....	87
FETCh:SUMMary:EVM:PCHannel:MINimum.....	87
FETCh:SUMMary:EVM:PCHannel[:AVERage].....	87
FETCh:SUMMary:EVM:PSIGnal:MAXimum.....	87
FETCh:SUMMary:EVM:PSIGnal:MINimum.....	87
FETCh:SUMMary:EVM:PSIGnal[:AVERage].....	87
FETCh:SUMMary:EVM:USQP[:AVERage].....	88
FETCh:SUMMary:EVM:USSF[:AVERage].....	89
FETCh:SUMMary:EVM:USST[:AVERage].....	89
FETCh:SUMMary:EVM[:ALL]:MAXimum.....	88
FETCh:SUMMary:EVM[:ALL]:MINimum.....	88
FETCh:SUMMary:EVM[:ALL][:AVERage].....	88
FETCh:SUMMary:FERRor:MAXimum.....	89
FETCh:SUMMary:FERRor:MINimum.....	89
FETCh:SUMMary:FERRor[:AVERage].....	89
FETCh:SUMMary:GIMBalance:MAXimum.....	89
FETCh:SUMMary:GIMBalance:MINimum.....	89
FETCh:SUMMary:GIMBalance[:AVERage].....	89
FETCh:SUMMary:IQOFset:MAXimum.....	90
FETCh:SUMMary:IQOFset:MINimum.....	90
FETCh:SUMMary:IQOFset[:AVERage].....	90
FETCh:SUMMary:POWer:MAXimum.....	90
FETCh:SUMMary:POWer:MINimum.....	90
FETCh:SUMMary:POWer[:AVERage].....	90
FETCh:SUMMary:QUADerror:MAXimum.....	90
FETCh:SUMMary:QUADerror:MINimum.....	90
FETCh:SUMMary:QUADerror[:AVERage].....	90
FETCh:SUMMary:SERRor:MAXimum.....	91
FETCh:SUMMary:SERRor:MINimum.....	91
FETCh:SUMMary:SERRor[:AVERage].....	91
FETCh:SUMMary:TFRame.....	91
FORMat[:DATA].....	91
INITiate:CONtinuous.....	92
INITiate:REFresh.....	93
INITiate[:IMMediate].....	92

INPut:EATT:AUTO.....	94
INPut:SElect.....	94
INPut<n>:ATTenuation<analyzer>.....	93
INPut<n>:DIQ:RANGe[:UPPer].....	93
INPut<n>:DIQ:SRATe.....	93
INSTRument:NSElect.....	96
INSTRument[:SElect].....	94
MMEMory:LOAD:DEModsettings.....	98
TRACe[:DATA].....	105
TRIGger[:SEquence]:HOLDoff<analyzer>.....	109
TRIGger[:SEquence]:LEVel<analyzer>[:EXTernal].....	110
TRIGger[:SEquence]:MODE.....	110
UNIT:BSTR.....	110
UNIT:EVM.....	111
[SENSe]:FREQuency:CENTer.....	102
[SENSe]:POWer:ACHannel:AACHannel.....	102
[SENSe]:POWer:AUTO<analyzer>:TIME.....	103
[SENSe]:POWer:AUTO<analyzer>[:STATe].....	102
[SENSe]:POWer:NCORrection.....	103
[SENSe]:POWer:SEM:CATegory.....	103
[SENSe]:SWAPiq.....	103
[SENSe]:SWEep:TIME.....	104
[SENSe][:LTE]:FRAMe:COUNT.....	98
[SENSe][:LTE]:FRAMe:COUNT:AUTO.....	99
[SENSe][:LTE]:FRAMe:COUNT:STATe.....	99
[SENSe][:LTE]:SLOT:SElect.....	99
[SENSe][:LTE]:SUBFrame:SElect.....	100
[SENSe][:LTE]:UL:DEMod:AUTO.....	100
[SENSe][:LTE]:UL:DEMod:CBSCrambling.....	100
[SENSe][:LTE]:UL:DEMod:CDCOffset.....	100
[SENSe][:LTE]:UL:DEMod:CESTimation.....	101
[SENSe][:LTE]:UL:DEMod:SISYnc.....	101
[SENSe][:LTE]:UL:TRACking:PHASe.....	101
[SENSe][:LTE]:UL:TRACking:TIME.....	101

# Index

## A

Adjacent Channel Leakage Ratio (ACLR) .....	50
Advanced Dialog .....	26
Advanced General Settings .....	26
Allocation Summary .....	55
Auto Demodulation .....	29
Auto Detection (Cell Identity) .....	32

## B

Bit Stream .....	56
------------------	----

## C

Capture Memory .....	46
Capture Time .....	23
CCDF .....	55
Cell ID .....	32
Cell Identity Group .....	32
Channel Bandwidth .....	21
Channel Estimation Range .....	29
Channel Flatness .....	52
Channel Flatness Difference .....	53
Channel Group Delay .....	52
Compensate DC Offset .....	29
Configurable Subframes .....	32
Configuration Table .....	32
Constellation Diagram .....	53
Constellation Selection .....	54

## D

Data Capture Settings .....	23
Demodulation Reference Signal	
Delta Sequence Shift .....	35
Enable n_PRS .....	35
Group Hopping .....	34
n_DRMS .....	35
Relative Power PUCCH .....	34
Relative Power PUSCH .....	34
Sequence .....	34
Sequence Hopping .....	35
DemodulationSettings .....	28
DFT Precod Constellation .....	54
Dialog	
Advanced .....	26
Marker .....	57
Marker Zoom .....	58
UL Demod .....	29
UL Frame Config .....	30
UL General .....	20
Digital Input Data Rate .....	28
Display Settings .....	43

## E

Electrical Attenuation .....	28
Eternal Trigger Level .....	25
EVM Result Displays .....	47
EVM vs Carrier .....	47
EVM vs Subframe .....	48
EVM vs Symbol .....	47
External Attenuation .....	23

## F

Frame Number Offset .....	32
Frequency .....	21
Frequency Sweep Measurements .....	49
Full Scale Level .....	28

## G

General Result Displays .....	46
General Settings .....	20

## H

HCOPY Key .....	43
Header Table .....	18

## I

I/Q Measurements .....	51
I/Q Settings .....	26
Identity (Physical Layer) .....	32
Inband Emission .....	51
Input Settings .....	26
Input Source .....	26
Interface .....	18

## K

key	
MODE (remote control) .....	94, 96
Key	
HCOPY .....	43
MKR .....	57
PRINT .....	43

## L

Level Settings .....	22
----------------------	----

## M

Marker Zoom .....	58
Measurement Settings .....	40
MKR Key .....	57

## N

Number of RB .....	21
--------------------	----

## O

online help	
working with .....	8

## P

Phase Error .....	30
Printer Settings .....	43
PRINT Key .....	43
PUCCH Structure	
Delta Offset .....	39
Delta Shift .....	39
Format .....	40
N_PUCCH .....	40

N(1)_cs .....	39	Frame Number Offset .....	32
N(2)_RB .....	40	Freq. Domain Pos. n_RRC .....	37
Number of RBs for PUCCH .....	39	Frequency .....	21
PUSCH Structure		Frequency Hopping Mode .....	38
Frequency Hopping Mode .....	38	Full Scale Level .....	28
Info. in Hopping Bits .....	38	Group Hopping .....	34
Number of Subbands .....	38	Hopping BW b_hop .....	37
PUSCH Hopping Offset .....	38	I/Q Settings .....	26
<b>R</b>		Identity .....	32
Reference Level .....	22, 27	Info. in Hopping Bits .....	38
Resource Blocks .....	21	Input Settings .....	26
Result Display		Level Settings .....	22
Adjacent Channel Leakage Ration (ACLR) .....	50	n_DRMS .....	35
Allocation Summary .....	55	n_PRS .....	35
Bit Stream .....	56	N_PUCCH .....	40
Capture Memory .....	46	N(1)_cs .....	39
CCDF .....	55	N(2)_RB .....	40
Channel Flatness .....	52	Number of RB .....	21
Channel Flatness Difference .....	53	Number of RBs for PUCCH .....	39
Channel Group Delay .....	52	Number of Subbands .....	38
Constellation Diagram .....	53	Phase .....	30
Constellation Measurements .....	53	Present .....	36
Constellation Selection .....	54	Printer .....	43
DFT Precod Constellation .....	54	PUSCH Hopping Offset .....	38
EVM Measurements .....	47	Ref Level .....	22, 27
EVM vs Carrier .....	47	Relative Power PUCCH .....	34
EVM vs Subframe .....	48	Relative Power PUSCH .....	34
EVM vs Symbol .....	47	Rel Power .....	36
Frequency Sweep Measurements .....	49	RF Att .....	27
General .....	46	Scrambling of coded bits .....	29
I/Q Measurements .....	51	Sequence .....	34, 36
Inband Emission .....	51	Sequence Hopping .....	35
Miscellaneous Measurements .....	55	Signal Characteristics .....	20
Result Summary .....	44	Source .....	26
Spectrum Emission Mask .....	49	SRS Bandwidth B_SRS .....	36
Statistical Measurements .....	55	SRS BW Conf. C_SRS .....	37
Result Summary .....	44	SRS Cyclic Shift N_CS .....	37
RF Attenuation .....	27	SRS Subframe Conf. .....	36
<b>S</b>		Standard .....	20
Scrambling of coded bits .....	29	suppressed interference synchronization .....	30
Screen Layout .....	18	Swap I/Q .....	26
Settings		TDD UL/DL Allocations .....	31
Advanced .....	26	Timing .....	30
Auto .....	32	Transm. Comb. K_TC .....	37
Auto Demodulation .....	29	Trigger .....	24
Capture Time .....	23	Trigger Holdoff .....	25
Cell ID .....	32	Trigger Hysteresis .....	25
Cell Identity Group .....	32	Trigger Mode .....	24
Channel Bandwidth .....	21	Trigger Offset .....	25
Channel Estimation Range .....	29	UL Demod .....	29
Compensate DC Offset .....	29	UL Frame Config .....	30
Conf. Index I_SRS .....	37	UL General .....	20
Configurable Subframes .....	32	Signal Characteristics .....	20
Data Capture .....	23	Softkey	
Delta Offset .....	39	ACLR .....	50
Delta Sequence Shift .....	35	Allocation Summary .....	55
Delta Shift .....	39	Bit Stream .....	56
Digital Input Data Rate .....	28	Capture Memory .....	46
Display .....	43	CCDF .....	55
EI Att .....	28	Channel Flatness .....	52
Ext Att .....	23	Const Diagram .....	53
Ext Trigger Level .....	25	Const Selection .....	54
Format .....	40	Demod Settings .....	28
		Display (List Graph) .....	44
		EL Atten Mode (Auto/Man) (remote control) .....	94
		EVM .....	47
		EVM vs Carrier .....	47

EVM vs Subframe .....	48
EVM vs Symbol .....	47
Flatness Difference .....	53
General Settings .....	20
Group Delay .....	52
Inband Emission .....	51
Marker 1 .....	57
Meas Settings .....	40
SEM .....	49
SEMDFT Precod Constell .....	54
Sounding Reference Signal	
Conf. Index I_SRS .....	37
Freq. Domain Pos. n_RRC .....	37
Hopping BW b_hop .....	37
Present .....	36
Rel Power .....	36
Sequence .....	36
SRS Bandwidth B_SRS .....	36
SRS BW Conf. C_SRS .....	37
SRS Cyclic Shift N_CS .....	37
SRS Subframe Conf. ....	36
Transm. Comb. K_TC .....	37
Source (Input) .....	26
Spectrum Emission Mask .....	49
Standard Selection .....	20
Status Bar .....	18
Status registers	
STATus:QUESTIONable:LIMit .....	112
STATus:QUESTIONable:SYNC .....	113
Subframe Configuration Table .....	32
Suppressed interference synchronization .....	30
Swap I/Q .....	26
<b>T</b>	
TDD UL/DL Allocations .....	31
Timing Error .....	30
Title Bar .....	18
Trigger Holdoff .....	25
Trigger Hysteresis .....	25
Trigger Mode .....	24
Trigger Offset .....	25
Trigger Settings .....	24
<b>U</b>	
UL Demod Settings .....	29
UL Frame Config Settings .....	30
UL General Settings .....	20
Using the Marker .....	57